



Achieving a Satisfactory Motor Carrier Safety Record

provided by



UTC
Washington Utilities
and Transportation
Commission

updated December 2020

Disclaimer:

- **THIS MANUAL IS NOT INTENDED TO BE A COMPLETE REFERENCE. USE IT ONLY AS A GUIDE IN COMPLYING WITH STATE AND FEDERAL SAFETY REGULATIONS.**
- **DO NOT USE THIS MANUAL AS THE BASIS FOR LEGAL INTERPRETATIONS.**

DO YOU KNOW . . .

HOW TO ACHIEVE A SATISFACTORY SAFETY RECORD?

Operators of commercial motor vehicles must comply with applicable state and federal safety regulations. This includes:

Private carriers	Tractor/trailers
For hire carriers	Passenger Vehicles
Trucks	Solid Waste collectors

Most companies operating commercial motor vehicles are subject to Compliance Reviews (CR). Personnel of the Washington Utilities and Transportation Commission (UTC), Federal Motor Carrier Safety Administration (FMCSA), or the Washington State Patrol (WSP) conduct the Reviews to measure carriers' compliance with applicable safety regulations.

The UTC distributes this manual to assist carriers in understanding applicable rules and being prepared for Safety Compliance Reviews.

Compliance with safety regulations requires that companies complete and maintain various safety forms. This manual contains sample copies of many of the required forms. Unless your company has already done so, complete the applicable forms and maintain the completed forms at your principal place of business. **Please make as many copies of each form as you need.** We provide these sample forms as a courtesy to carriers. Carriers are not required to use these specific forms, they may use substitute forms obtained from other sources. Carriers must have all applicable driver and equipment safety records available for inspection when requested.

If you have questions or require additional information, please call:

Washington Utilities and Transportation Commission
Motor Carrier Safety
621 Woodland Square Loop SE
Lacey, WA 98503
or
P. O. Box 47250
Olympia, WA 98504-7250
(360) 664-1244
www.utc.wa.gov

NOTE: This publication not intended for sale.

Table of Contents

Introduction	5
Abbreviations & Acronyms	7
Definitions	9
Section 1	
Controlled Substances and Alcohol Use Testing (49 CFR, Part 382 and Part 40).....	15
Section 2	
Commercial Driver’s License Standards Requirements and Penalties (49 CFR, Part 383)	41
Section 3	
Qualifications of Drivers (49 CFR, Part 391)	51
Section 4	
Driver Operation (49 CFR, Part 392)	87
Section 5	
Insurance Requirements	93
Section 6	
Parts and Accessories Necessary For Safe Operation (49 CFR, Part 393)	107
Section 7	
Accidents	115
Section 8	
Drivers Hours of Service (49 CFR, Part 395)	125
Section 9	
Inspection Repair and Maintenance (49 CFR, Part 396)	141
Section 10	
Transportation of Hazardous Material (49 CFR, Part 397)	165
Section 11	
Commercial Vehicle Safety Alliance	169
Section 12	
Safety Compliance Review	175
Section 13	
Suggestions for Establishing an Effective Safety Program	181
Section 14	
Marking of Vehicles	187
Section 15	
Bus Operations	191
Section 16	
Record Keeping Requirements of the Federal Motor Carrier Safety Regulation	199
Section 17	
Leasing Requirements	209
Section 18	
CSA (Compliance, Safety & Accountability)	215

INTRODUCTION

The Washington Utilities and Transportation Commission (UTC) administers and enforces Washington Administrative Code regulations (WAC), federal safety rules (FMCSR) and state laws (RCW) relating to motor vehicle safety.

Safety Program Mission:

- To enforce state and federal laws, rules and regulations.
- To educate motor carriers and general public.
- To assist motor carriers in achieving and maintaining compliance.

Safety Program Objectives:

- To reduce commercial motor vehicle accidents.
- To decrease fatalities, injuries and property losses involving commercial motor vehicles.

Purpose of This Manual:

- This manual is designed to assist carriers in gaining a basic knowledge of the laws and rules relating to motor carrier safety.

Disclaimer:

- **THIS MANUAL IS NOT INTENDED TO BE A COMPLETE REFERENCE.** Use it only as a guide in complying with state and federal safety regulations.
- **DO NOT** use this manual as the basis for legal interpretations.

FEDERAL SAFETY REGULATIONS:

The public may review copies of federal safety regulations at the UTC branch of the Washington State Library, located in the Lacey Headquarters offices of the Commission. You may obtain copies from:

- The UTC (subject to pertinent copying charges).
- The Government Printing Office, Seattle, Washington.
- Web page <http://www.fmcsa.dot.gov>.
- Numerous other private vendors.

UTC SAFETY REGULATIONS:

For those carriers subject to Commission regulation, the UTC publishes rulebooks containing complete carrier regulations (excluding Federal Regulations). The rulebooks are available, free of charge, by contacting:

Washington Utilities and Transportation Commission
Attn: Records Center
P. O. Box 47250
Olympia, Washington 98504-7250
Telephone: (360) 664-1234

Note: Carriers are responsible for knowing and complying with all state and federal safety regulations, whether or not they are discussed in this manual.

NOTE: Drivers who operate for carriers regulated by the UTC may have additional requirements regarding medical certification and driver qualifications. Those requirements should be reviewed by checking the applicable Washington Administrative Code (WAC).

ABBREVIATIONS AND ACRONYMS

The following abbreviations and acronyms are used throughout this manual:

<u>Abbreviation/Acronym</u>	<u>Meaning</u>
BAC	Breath Alcohol Concentration
BASIC.....	Behavior Analysis Safety Improvement Categories
BAT	Breath Alcohol Technician
CDL	Commercial Driver’s License
CDLIS	Commercial Driver’s License Information System
CFR	Code of Federal Regulations
CMV	Commercial Motor Vehicle
Commission	Washington Utilities and Transportation Commission
CSL	Combined Single Limit
CSA.....	Compliance Safety Accountability
CVSA	Commercial Vehicle Safety Alliance
DHHS	Department of Health and Human Services (federal)
DOL	Department of Licensing
DOT	Department of Transportation (federal)
DVIR	Driver Vehicle Inspection Report
EBT	Evidential Breath Testing Device
ELD.....	Electronic Logging Device
FHWA	Federal Highway Administration
FMCSA	Federal Motor Carrier Safety Administration
FMCSR	Federal Motor Carrier Safety Regulation
FMVSS	Federal Motor Vehicle Safety Standards
GCVWR	Gross Combined Vehicle Weight Rating
GVWR	Gross Vehicle Weight Rating
HAZMAT	Hazardous Material
HMR	Hazardous Material Regulation
HMT	Hazardous Material Transportation
MCSR	Motor Carrier Safety Regulation
MRO	Medical Review Officer
MV	Motor Vehicle
NAS	North American Standard
NHTSA	National Highway Traffic Safety Administration
RCW	Revised Code of Washington (state statutes)
RODS	Records of Duty Status
SAP	Substance Abuse Professional
SMS	Safety Measurement System
UL	Underwriters’ Laboratory Rating
USDOT	United States Department of Transportation
UTC.....	Utilities and Transportation Commission
WAC	Washington Administrative Code
WSP	Washington State Patrol
WUTC	Washington Utilities and Transportation Commission

DEFINITIONS

Accident means an occurrence involving a commercial motor vehicle operating on a highway in interstate or intrastate commerce that results in:

- (i) A fatality.
- (ii) Bodily injury to a person who, as a result of the injury, immediately receives medical treatment away from the scene of the accident.
- (iii) One or more motor vehicles incurring disabling damage as a result of the accident, requiring the motor vehicles to be transported away from the scene by a tow truck or other motor vehicle.

Adverse driving conditions means snow, sleet, fog, other adverse weather conditions, a highway covered with snow or ice, or unusual road and traffic conditions, none of which were apparent on the basis of information known to the person dispatching the run at the time it was begun.

Alcohol means the intoxicating agent in beverage alcohol, ethyl alcohol, or other low molecular weight alcohols including methyl and isopropyl alcohol.

Auto Transportation Vehicle means any motor-propelled vehicle used in Auto Transportation operations.

Charter Bus and Excursion Bus means any vehicle with a seating capacity for seven or more persons, excluding the driver.

Collection Site means a place where individuals present themselves for the purpose of providing breath, body fluid, or tissue samples to be analyzed for specific controlled substances.

Commerce when used in this document means the exchange or buying and selling of commodities (products and services), involving transportation from place to place

Commercial Driver's License (CDL) means a license issued in accordance with the requirements of 49 CFR, Part 383, to an individual that authorizes the individual to drive a class of commercial motor vehicle.

Commercial Motor Vehicle (CMV) (General definitions) means any self-propelled or towed motor vehicle used on a public highway in commerce, to transport passengers or property, when the vehicle:

- (1) Has a gross vehicle weight rating or gross combination weight rating, or gross vehicle weight or gross combination weight, of 4,536 kg (10,001 pounds) or more, whichever is greater.
- (2) Is designed or used to transport more than 8 passengers, including the driver, for compensation.
- (3) Is designed or used to transport more than 15 passengers, including the driver and is not used to transport passengers for compensation.
- (4) Is used in transportation of material found by the Secretary of USDOT to be hazardous under 49 U.S.C. 5103 and transported in a quantity requiring placarding under Regulations prescribed by the Secretary under 49 CFR, subtitle B, Chapter I, subchapter C.

Exceptions to general definitions of CMV:

- (a) Vehicles operating as Auto Transportation Carriers, Charter Carriers, or Excursion Carriers as defined in Chapter 81.68 RCW, and 81.70 RCW, respectively.
- (b) If the vehicle is a school bus as defined in RCW 46.04.521, regardless of weight or size.
- (c) Vehicles operating under the provisions of RCW 46.25.010(6), exclusively in intrastate commerce.

Common Carrier means any person who undertakes to transport property, including general commodities, household goods, materials transported by armored car service and/or hazardous materials, for the general public, for compensation over the public highways of the State of Washington.

Controlled Substances means the presence of the following substances:

- (a) Marijuana
- (b) Cocaine
- (c) Opioids
- (d) Amphetamines
- (e) Phencyclidine (PCP)

Disabling Damage means damage that precludes departure of a motor vehicle from the scene of the accident, in its usual manner, in daylight, after simple repairs.

- (1) Inclusions: Damage to motor vehicles that could have been driven, but would have been further damaged if so driven.
- (2) Exclusions:
 - (i) Damage that can be remedied temporarily at the scene of the accident without special tools or parts.
 - (ii) Tire disablement without other damage, even if no spare tire is available.
 - (iii) Headlight or taillight damage.
 - (iv) Damage to turn signals, horns, or windshield wipers that make them inoperative.

Driving Time means all time spent at the driving controls of a commercial motor vehicle in operation.

Electronic Logging Device means electronic hardware used to record the working hours of a commercially-operated motor vehicle.

Farm Vehicle Driver means a person who drives only a commercial motor vehicle that is controlled and operated by a farmer as a private motor carrier of property, if the vehicle:

- (1) Is being used to transport either:
 - (a) Agricultural products.
 - (b) Farm machinery, farm supplies, or both, to or from a farm.
- (2) Is not being used in the operation of a for-hire motor carrier.
- (3) Is not carrying hazardous materials of a type or quantity that requires the commercial motor vehicle to be placarded in accordance with §177.823 of Title 49 CFR.
- (4) Is being used within 150 air miles of the farmer's farm.

For-hire Motor Carrier means a person engaged in the transportation of goods or passengers for compensation.

Gross Combination Weight Rating means the value specified by the manufacturer as the loaded weight of a combination (articulated) motor vehicle.

Gross Vehicle Weight Rating means the value specified by the manufacturer as the loaded weight of a single motor vehicle.

Hazardous Material means a substance or material that has been determined by the Secretary of Transportation to be capable of posing an unreasonable risk to health, safety, and property when transported in commerce, and that has been so designated.

Interstate Commerce means trade, traffic, or transportation:

- (1) Between a place in a state and a place outside of such state (including a place outside the United States).
- (2) Between two places in a state through another state or a place outside of the United States.
- (3) Between two places in a state as part of trade, traffic, or transportation originating or terminating outside the state or the United States.

Intrastate Commerce means any trade, traffic, or transportation in any state from point A to point B within the State and not destined for interstate commerce.

Medical Review Officer means a licensed Medical Doctor or Doctor of Osteopathy with knowledge of drug abuse disorders who is employed or used by a motor carrier to conduct drug testing in accordance with 49 CFR, Part 40.

Multiple-employer driver means a driver, who in any period of seven consecutive days, is employed or used as a driver by more than one motor carrier.

On-duty Time means all time from the time a driver begins work, or is required to be in readiness to work, until the time he/she is relieved from work and all responsibility for performing work, including:

- (1) All time at a carrier or shipper plant, terminal, or facility, or other property, or on any public property waiting to be dispatched, unless the driver has been relieved from duty by the motor carrier.
- (2) All time inspecting, servicing, or conditioning any commercial motor vehicle, at any time.
- (3) All driving time.
- (4) All time, other than driving time, in or on any commercial motor vehicle except time spent resting in a sleeper berth.
- (5) All time loading or unloading a vehicle, supervising, or assisting in the loading or unloading, attending a vehicle being loaded or unloaded, remaining in readiness to operate the vehicle, or in giving or receiving receipts for shipments loaded or unloaded.
- (6) All time repairing, obtaining assistance, or remaining in attendance on a disabled vehicle.
- (7) On duty time does not include any time resting in a parked vehicle (property or passenger carriers) or up to two hours riding in the passenger seat of a moving property carrier vehicle immediately before or after a period of at least 8 consecutive hours in the sleeper berth.
- (8) Performing any other work in the capacity, employ, or service of, a motor carrier; and
- (9) Performing any compensated work for a person who is not a motor carrier.

Out-of-service Order means a declaration by an authorized enforcement officer of a federal, state, Canadian, Mexican or local jurisdiction that a driver, a commercial motor vehicle, or a motor carrier operation, is out of service pursuant to CFR 49 Parts 386.72, 392.5, 395.13, 396.9, or compatible laws, or the North American Uniform Out-of-Service Criteria.

Principal Place of Business means the single location designated by the motor carrier, normally its headquarters, for purposes of identification under 49 CFR. The motor carrier must make records required by Title 49 CFR available for inspection at this location within 48 hours (Saturdays, Sundays, and Federal holidays excluded) after a request has been made by a special agent or authorized representative of the FMCSA, UTC or WSP.

Private Motor Carrier means a person who provides transportation of property or passengers, by commercial motor vehicle, and is not a for-hire carrier.

Private Non-profit Commercial Motor Vehicle means any motor vehicle designed to transport sixteen or more passengers, including the driver.

Private Non-profit Motor Vehicle means any self-propelled vehicle with seating capacity of seven or more persons, including the driver.

Private Non-profit Provider means a private, non-profit corporation providing transportation services for compensation, to persons with special transportation needs.

Reasonable suspicion means that the motor carrier believes the actions, appearance, or conduct of a commercial motor vehicle driver who is on duty as defined, are indicative of the use of a controlled substance.

Registered Carrier means a carrier operating in interstate or foreign commerce under authority issued by the Federal Motor Carrier Safety Administration.

Registered Exempt Carrier means a carrier operating in interstate or foreign commerce under the exemptions of the Federal Motor Carrier Act, without interstate authority issued by the Federal Motor Carrier Safety Administration.

Safety-sensitive Function means:

- (1) Time at a carrier or shipper plant, terminal, facility, or other property, waiting to be dispatched.
- (2) Time inspecting equipment as required by 49 CFR, 392.8, or otherwise inspecting, servicing, or conditioning a commercial motor vehicle.
- (3) Time spent driving.
- (4) Time spent in or on any commercial vehicle (excluding sleeper berth time).
- (5) Time spent loading or unloading a vehicle, supervising or assisting in the loading or unloading, attending a vehicle being loaded or unloaded, remaining in readiness to operate the vehicle, or in giving or receiving receipts for shipments loaded or unloaded.
- (6) Time spent performing driver requirements relating to accidents.
- (7) Time spent repairing, obtaining assistance, or remaining in attendance on a disabled vehicle.

School Bus Operation means the use of a school bus to transport school children and/or school personnel from home to school and from school to home, and to school sponsored events. School bus does not include a bus used as a common carrier.

Sleeper berth means a berth conforming to the requirements of 49 CFR, Part 393.76.

Section 1

Controlled Substances And Alcohol Use Testing

(49 CFR, Part 382 and Part 40)

APPLICABILITY:

These rules apply to drivers who are required to possess a commercial driver's license (CDL). This includes:

- For-hire and private carriers.
- Federal, state, local, and tribal governments.
- Apiaries industries.
- Church and civic organizations.

Exemptions – interstate and intrastate:

- Active duty military personnel.

Exemptions – Washington intrastate only:

- Farmer in vehicle licensed for no more than 40,000 pounds and hauling agricultural products, supplies, or machinery within 150 miles of the farm, and not used in common or contract carrier operations.
- Fire fighter or law enforcement officer that has a certification of completion of specialized training course approved by the Department of Licensing.
- Recreational vehicle for non-commercial uses.

Subpart B – Prohibitions

The following are prohibitions for drivers and/or motor carriers regarding controlled substance and/or alcohol use during the performance of safety-sensitive functions:

§382.201	Alcohol concentration
§382.205	On-duty use
§382.207	Pre-duty use
§382.209	Use following an accident
§382.211	Refusal to submit to a required alcohol or controlled substances test
§382.213	Controlled substances use
§382.215	Controlled substances testing

*NOTE: Positive controlled substance and/or alcohol tests will require a driver to be removed from safety-sensitive functions.

TYPES OF CONTROLLED SUBSTANCE AND ALCOHOL TESTS TO BE PERFORMED:

- Pre-employment (controlled substance only)
- Post-accident
- Random
- Reasonable suspicion
- Return-to-duty
- Follow-up

Pre-employment: No employer shall allow a driver to perform a safety-sensitive function until they have received written notifications of a negative controlled substance test result.

Post-accident: Every driver involved in a recordable accident shall be tested for controlled substances and alcohol use if:

- The accident involved the loss of human life.
- If the driver received a citation and any vehicles involved in the accident were towed away from the scene.
- If the driver received a citation and any person(s) involved in the accident required immediate treatment away from the accident scene.

Post-Accident Drug & Alcohol Test Requirements		
Type of Accident	Citation issued to Driver?	Must test be performed by employer?
Involves human	Yes	Yes
fatality	No	Yes
Involves bodily injury with treatment away from accident scene	Yes	Yes
Disabling damage to any motor vehicle (requiring towing)	Yes	Yes

- (1) Test should be conducted as soon as possible:
 - (a) Alcohol within eight hours; and
 - (b) Controlled substance within 32 hours.
- (2) If testing cannot be conducted within time limits, carrier must document the reason.

Random: Carriers must randomly test their drivers according to the following rates. The tests must be unannounced and for alcohol testing, must be conducted immediately prior to, during, or immediately following a safety-sensitive function.

- Controlled substances: 50% of drivers over a twelve-month period.
- Alcohol: 10% of average number of driver positions, over a twelve-month period.

Note: Percentages set by the FMCSA Administrator on an annual basis and subject to change

Reasonable Suspicion: Initiated by a trained supervisor who shall require a driver to submit to a controlled substance and/or alcohol use test when that supervisor has reasonable suspicion that a driver is in violation of the rules that prohibit the use of controlled substances and alcohol during safety-sensitive functions.

Note: Each employer shall ensure that all persons designated to supervise drivers receive at least 60 minutes of training on alcohol misuse and receive at least an additional 60 minutes of training on controlled substances use.

Return to duty: A driver who has engaged in conduct prohibited by subpart B of Part 382, shall undergo a return to duty alcohol test with an alcohol concentration of less than .02, and/or a negative controlled substance test, prior to performing any safety-sensitive function.

Follow-up: Applies to any driver who, upon referral by a Substance Abuse Professional (SAP) for engaging in conduct prohibited by subpart B of Part 382, must undergo follow-up testing. If referred, the driver must undergo a minimum of six (6) tests over a twelve-month period, for a maximum period of 60 months.

PREVIOUS EMPLOYER CONTROLLED SUBSTANCE & ALCOHOL TEST INQUIRY

Employers shall request alcohol and controlled substance testing information from previous employers in accordance with the requirements of 49 CFR, Part 40.25. This request shall be made pursuant to the employee's written consent.

The following information must be requested from previous DOT-regulated employers who have employed the employee for any period during the two years prior to the date of the employee's application:

- Alcohol tests with a result of 0.04 or higher alcohol concentration.
- Verified positive drug tests.
- Refusals to be tested (including verified adulterated or substituted drug test results).
- Other violations of DOT agency drug and alcohol testing regulations.
- With respect to any employee who violated DOT drug and/or alcohol regulations, if this information cannot be obtained from the previous employer, it shall be obtained from the employee.

If possible, this information should be obtained before the employee first performs safety-sensitive functions. If this is not possible, the employer must obtain and review the information as soon as possible. No employee shall be permitted to perform safety-sensitive functions after 30 days from the date on which the employee first performed safety-sensitive functions, unless the employer has obtained OR made and documented a good-faith effort to obtain the information.

This requirement applies only to employees seeking to begin performing safety-sensitive functions for employers for the first time (i.e., a new hire, an employee that transfers into a safety-sensitive position). If the employee refuses to provide written consent, the employer must not permit the employee to perform safety-sensitive functions.

RETENTION OF RECORDS - 49 CFR 382.401**One year:**

- Negative and cancelled drug test results.
- Alcohol test results indicating a breath alcohol concentration less than 0.02.

Two years:

- Records related to the collection process and required training.

Five Years:

- Alcohol test results indicating a breath alcohol concentration (BAC) of 0.02 or greater.
- Verified positive drug test results.
- Any refusals to submit to required alcohol and/or drug tests.
- Required calibration results of EBT devices.
- Substance abuse professional's (SAP's) evaluations and referrals.
- Annual calendar year summary.

LOCATION OF REQUIRED RECORDS

- Must be maintained in a secure location.
- Must have limited access.
- Records shall be made available for inspection by authorized representatives of the FMCSA, UTC, and WSP.

SUPERVISOR TRAINING

- 60 minutes of training on alcohol abuse.
- 60 minutes of training on controlled substance abuse.
- Supervisors shall use this training to determine if reasonable suspicion testing is required on a driver.
- Training shall include physical, behavioral, speech, and performance indicators of alcohol and controlled substance misuse.

CONTROLLED SUBSTANCE AND ALCOHOL POLICY AND TRAINING

The employer shall provide educational materials that explain the following:

- The identity of carrier official designated to answer driver questions regarding controlled substance and alcohol testing.
- Which drivers are subject to Part 382.
- Information regarding what safety-sensitive functions are and when a driver is required to be in compliance with this part.
- What types of driver conduct are prohibited by Part 382.
- Procedures used in testing for controlled substances and alcohol.
- Explanation of what constitutes a refusal to submit to controlled substance and alcohol testing; and the consequences of such refusal.
- Requirement that a driver submit to required testing under Part 382.
- Consequences for any driver violating subpart B of Part 382.
- Information concerning the effects of controlled substance and alcohol use.
- The reporting requirements to the Drug and Alcohol Clearinghouse.

DRIVER CERTIFICATE OF RECEIPT

Each employer shall require each driver to sign a statement certifying that the driver has received the aforementioned information. This certification shall be maintained by the employer, subject to inspection by representatives of the FMCSA, UTC, and WSP.



U.S. Department of Transportation
Federal Motor Carrier Safety
Administration

U.S. Department of Transportation Drug & Alcohol Supervisor Training Guidance

August 27, 2015

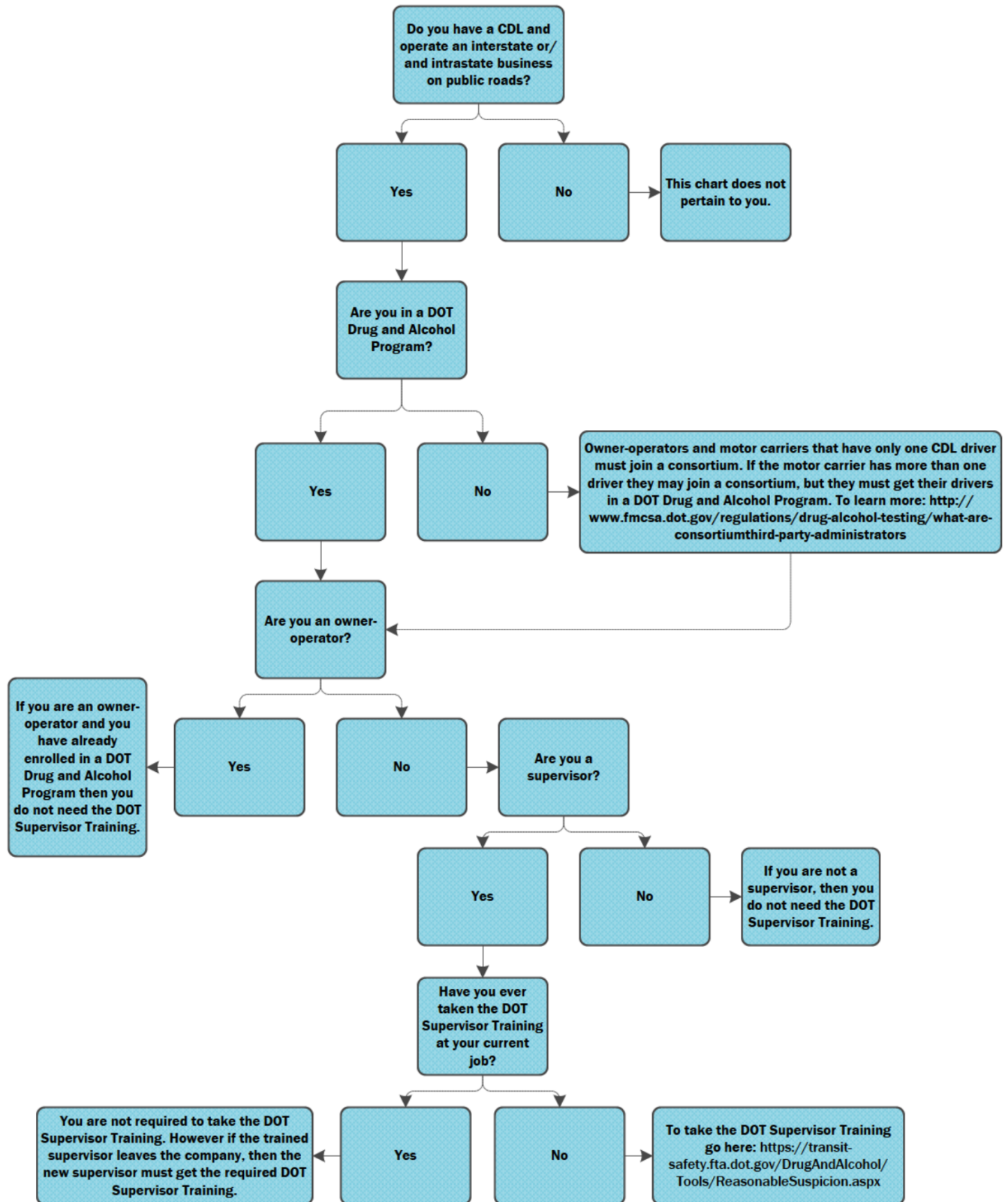

COMMERCIAL DRIVER'S LICENSE (CDL) DRUG AND ALCOHOL CLEARINGHOUSE

This online database helps keep roads safer for all drivers by identifying, in real time, drivers prohibited from performing safety-sensitive functions, such as operating a commercial motor vehicle (CMV), due to a drug and alcohol program violation.

The Federal Motor Carrier Administration (FMCSA) established the Commercial Driver's License (CDL) Drug and Alcohol Clearinghouse (Clearinghouse). This database contains information pertaining to violations of the U.S. Department of Transportation (DOT) controlled substances (drug) and alcohol testing program for holders of CDLs.

The Clearinghouse rule requires FMCSA-regulated employers, medical review officers (MROs), substance abuse professionals (SAPs), consortia/third party administrators (C/TPAs), and other service agents to report to the Clearinghouse information related to violations of the drug and alcohol regulations in 49 Code of Federal Regulations, Parts 40 and 382 by current and prospective employees.

The Clearinghouse final rule requires the following:

- Employers must query the Clearinghouse for current and prospective employees' drug and alcohol violations before permitting those employees to operate a commercial motor vehicle (CMV) on public roads.
- Employers must annually query the Clearinghouse for each driver they currently employ.

The Clearinghouse provides FMCSA and employers the necessary tools to identify drivers who are prohibited from operating a CMV based on DOT drug and alcohol program violations and ensure that such drivers receive the required evaluation and treatment before operating a CMV on public roads. Specifically, information maintained in the Clearinghouse enables employers to identify drivers who commit a drug or alcohol program violation while working for one employer, but who fail to subsequently inform another employer (as required by current regulations). Records of drug and alcohol program violations will remain in the Clearinghouse for five years, or until the driver has completed the return-to-duty process, whichever is later.

For further information for drivers and employers, including registration information, visit clearinghouse.fmcsa.dot.gov/learn.

APPENDIX B

DRIVER NOTIFICATION LETTER

I certify that I have received a copy of, and have read, the above __ (Company) __ policy on alcohol and drug testing procedures.

I understand that as a condition of employment as a driver I must comply with these guidelines, and do agree that I will remain medically qualified by following these procedures.

If I develop a problem with alcohol or drug abuse during my employment with __ (Company) __, I will seek assistance through the current alcohol and drug testing program administrator.

Signature _____

Date Signed _____

Employer: Retain in Employee's Confidential File

Alcohol and Controlled Substance Employee's Certified Receipt

Employee's Name

Company/Department

This is to certify that I have been provided educational materials that explain the requirements of 382.601 and my employer's policies and procedures with respect to meeting the requirements. The materials include detailed discussion of the following checked (√) items:

- _____ 1. The designated person to answer questions about the materials.
- _____ 2. The categories of drivers subject to Part 382.
- _____ 3. Sufficient information about the safety-sensitive functions and periods of the workday that compliance is required.
- _____ 4. Specific information concerning prohibited driver conduct.
- _____ 5. Circumstances under which a driver will be tested.
- _____ 6. Test procedures, driver protection and integrity of the testing process, and safeguarding the validity of the test.
- _____ 7. The requirement that tests are administered in accordance with Part 382.
- _____ 8. An explanation of what will be considered a refusal to submit to a test and the consequences.
- _____ 9. The consequences of Part 382 Subpart B violations including removal from safety-sensitive functions and 382.605 procedures.
- _____ 10. The consequences for drivers found to have an alcohol concentration of 0.02 or greater but less than 0.04.
- _____ 11. Information on the affect of alcohol and controlled substances use on:
 - › an individual's health
 - › signs and symptoms of a problem
 - › work
 - › personal life
 - › available methods of intervening when a problem is suspected
- _____ 12. Optional information:

 Employee's Signature

 Date

 Authorized Employer Representative

 Date

Employer: Retain in Employee's Confidential File

U.S. DEPARTMENT OF TRANSPORTATION DRUG AND ALCOHOL TESTING MIS DATA COLLECTION FORM

Calendar Year Covered by this Report: _____

OMB No. 2105-0529

Form DOT F 1385 (Rev. 4/2019)

I. Employer:

Company Name: _____

Doing Business As (DBA) Name (if applicable): _____

Address: _____ E-mail: _____

Name of Certifying Official: _____ Signature: _____

Telephone: (____) _____ Date Certified: _____

Prepared by (if different): _____ Telephone: (____) _____

C/TPA Name and Telephone (if applicable): _____ (____) _____

Check the DOT agency for which you are reporting MIS data; and complete the information on that same line as appropriate:

___ FMCSA – Motor Carrier: DOT #: _____ Owner-operator: (circle one) YES or NO Exempt (Circle One) YES or NO

___ FAA – Aviation: Certificate # (if applicable): _____ Plan / Registration # (if applicable): _____

___ PHMSA – Pipeline: (Check) Gas Gathering ___ Gas Transmission ___ Gas Distribution ___ Transport Hazardous Liquids ___ Transport Carbon Dioxide

___ FRA – Railroad: Total Number of observed/documentated Part 219 “Rule G” Observations for covered employees: _____

___ USCG – Maritime: Vessel ID # (USCG- or State-Issued): _____ (If more than one vessel, list separately.)

___ FTA – Transit

II. Covered Employees: (A) Enter Total Number Safety-Sensitive Employees In All Employee Categories:

(B) Enter Total Number of Employee Categories:

Employee Category	Total Number of Employees in this Category

If you have multiple employee categories, complete Sections I and II (A) & (B). Take that filled-in form and make one copy for each employee category and complete Sections II (C), III, and IV for each separate employee category.

III. Drug Testing Data

Type of Test	1 Total Number Of Test Results [Should equal the sum of Columns 2, 3, 9, 10, 11, and 12]	2 Verified Negative Results	3 Verified Positive Results -- For One Or More Drugs	4 Positive For Marijuana	5 Positive For Cocaine	6 Positive For PCP	7 Positive For Opioids	8 Positive For Amphetamines	Refusal Results				13 Cancelled Results
									9 Adulterated	10 Substituted	11 “Shy Bladder” ~ With No Medical Explanation	12 Other Refusals To Submit To Testing	
Pre-Employment													
Random													
Post-Accident													
Reasonable Susp./Cause													
Return-to-Duty													
Follow-Up													
TOTAL													

IV. Alcohol Testing Data:

Type of Test	1 Total Number Of Screening Test Results [Should equal the sum of Columns 2, 3, 7, and 8]	2 Screening Tests With Results Below 0.02	3 Screening Tests With Results 0.02 Or Greater	4 Number Of Confirmation Tests Results	5 Confirmation Tests With Results 0.02 Through 0.039	6 Confirmation Tests With Results 0.04 Or Greater	Refusal Results		Cancelled Results
							7 “Shy Lung” ~ With No Medical Explanation	8 Other Refusals To Submit To Testing	
Pre-Employment									
Random									
Post-Accident									
Reasonable Susp./Cause									
Return-to-Duty									
Follow-Up									
TOTAL									

Employer: Retain in Employee’s Confidential File

Observed Behavior – Reasonable Suspicion Record

DRIVER'S NAME		DATE OBSERVED:	
ADDRESS OF INCIDENT		TIME OBSERVED:	
Street _____	City _____	State _____	Zip _____
From _____ a.m. or p.m.		To _____ a.m. or p.m.	

Record employee observed behavior for reasonable suspicion for the use of alcohol or controlled substances. Per DOT requirements for reasonable suspicion testing, the employer shall require the driver to submit to a controlled substance or alcohol test if a supervisor or company official who is trained in accordance with §382.603 determines that reasonable suspicion exists.

Reasonable suspicion determined for: <input type="checkbox"/> Alcohol <input type="checkbox"/> Controlled Substances			
Mark items that apply and describe specifics			
1. APPEARANCE: Normal ___ Sleepy ___ Tremors ___ Clothing ___ Cleanliness ___ Description: _____			
2. BEHAVIOR: Normal ___ Erratic ___ Irritable ___ Inappropriate gaiety ___ Mood swings ___ Lethargic ___ Description: _____			
3. SPEECH: Description: _____			
4. BODY ODORS: _____			
5. INDICATIONS OF THE CHRONIC AND WITHDRAWAL EFFECTS OF CONTROLLED SUBSTANCES: <input type="checkbox"/> YES <input type="checkbox"/> NO Explain: _____			
6. OTHER OBSERVATIONS FOR REASONABLE SUSPICION: Explain: _____			
<u>WITNESSED BY:</u>			
_____ Signature	_____ Title	_____ Preparation Date	_____ Time a.m. or p.m.
_____ Signature	_____ Title	_____ Preparation Date	_____ Time a.m. or p.m.
The alcohol test must be administered within eight hours following a reasonable suspicion determination. <u>EMPLOYEE'S ACKNOWLEDGMENT AND CONSENT:</u> I acknowledge that I have been informed of the company's reasons for requesting this drug and/or alcohol testing and consent to the testing.			
_____ Employee Signature		_____ Date	



Positive/Refused Drug/Alcohol Test Report by Employer

Employers use this form to report a positive or refused drug or alcohol test by a driver. **A positive test result must include a copy of our [Positive/Refused Drug/Alcohol Test Report \(DR-500-013\)](#) completed by the Medical Review Officer/Breath Alcohol Technician.** When completed, mail or fax this form and any required attachments to:

Suspensions
Department of Licensing
PO Box 9030
Olympia, WA 98507-9030
 Fax: (360) 570-7826

Driver name <i>(Last, First, Middle Initial)</i>				
Driver license number	Date of birth	Last 4 digits of Social Security number Used for identification purposes. 42 USC 405(c)(2)(C). XXX-XX-		
Employer/Motor carrier/Consortium name				
Employer/Motor carrier/Consortium mailing address		City	State	ZIP Code
(Area code) Employer telephone number		Employer email address		
Reason for selection <input type="checkbox"/> Pre-employment <input type="checkbox"/> Random <input type="checkbox"/> Reasonable suspicion <input type="checkbox"/> Post accident <input type="checkbox"/> Return to duty <input type="checkbox"/> Follow-up				
Test results The driver above has: <input type="checkbox"/> Tested positive for drugs/alcohol on _____ Date <i>(mm/dd/yyyy)</i> . (attach report DR-500-013) <input type="checkbox"/> Refused test on _____ Date <i>(mm/dd/yyyy)</i> by: <input type="checkbox"/> Failed to appear for testing <input type="checkbox"/> Based on Positive/Refused Drug/Alcohol Test Report (attach report DR-500-013) <input type="checkbox"/> Other:				

As the employer, motor carrier, or consortium, having a program subject to federal requirements under 49 CFR 40 or 655, I declare under penalty of perjury under the laws of the state of Washington that on the date of this test the foregoing and any attachments and information contained therein is true and correct.

Date and place	PRINT or TYPE name Title X Signature of employer, motor carrier, or consortium
----------------	--

RCW 46.25.123

DR-500-005 (R/12/13)WA



FEDERAL DRUG TESTING CUSTODY AND CONTROL FORM



SPECIMEN ID NO. 0000001

STEP 1: COMPLETED BY COLLECTOR OR EMPLOYER REPRESENTATIVE

ACCESSION NO.

Form section for Step 1 containing fields for Employer Name, MRO Name, Donor SSN, Testing Authority, Reason for Test, Drug Tests, and Collection Site Address.

STEP 2: COMPLETED BY COLLECTOR (make remarks when appropriate) Collector reads specimen temperature within 4 minutes.

Form section for Step 2 containing fields for Temperature, Collection type, and Remarks.

STEP 3: Collector affixes bottle seal(s) to bottle(s). Collector dates seal(s). Donor initials seal(s). Donor completes STEP 5 on Copy 2 (MRO Copy)

STEP 4: CHAIN OF CUSTODY - INITIATED BY COLLECTOR AND COMPLETED BY TEST FACILITY

Form section for Step 4 containing signature and date fields for the collector, and fields for specimen bottle release and delivery service.

Form section for Step 4 containing signature and date fields for the accessioner, and fields for primary specimen bottle seal integrity and specimen bottle release.

STEP 5A: PRIMARY SPECIMEN REPORT - COMPLETED BY TEST FACILITY

Form section for Step 5A containing checkboxes for test results: Negative, Positive (Marijuana, Cocaine, Amphetamine, MDA, Morphine, Codeine), Rejected, Adulterated, Substituted, Invalid Result, and Dilute.

Form section for Step 5A containing Remarks, Test Facility name, certifying technician signature, and name/date fields.

STEP 5b: COMPLETED BY SPLIT TESTING LABORATORY

Form section for Step 5b containing Laboratory Name/Address, Reconfirmed/Failed to Reconfirm status, certifying scientist signature, and name/date fields.

Form section for bottle seals containing barcode, specimen ID, 'PLACE OVER CAP' instructions, and fields for date and initials for both main and split specimens.

COPY 1 - TEST FACILITY COPY

Version C 14/May/2010

OMB No. 0930-0158

PRESS HARD - YOU ARE MAKING MULTIPLE COPIES

80308

U.S. Department of Transportation (DOT) Alcohol Testing Form

(The instructions for completing this form are on the back of Copy 3)

Step 1: TO BE COMPLETED BY ALCOHOL TECHNICIAN

A: Employee Name _____
(Print) (First, M.I., Last)

B: SSN or Employee ID No. _____

C: Employer Name _____
 Street _____
 City, State, Zip _____

DER Name and Telephone No. _____
()
 DER Name _____ DER Phone Number _____

D: Reason for Test: Random Reasonable Susp Post-Accident Return to Duty Follow-up Pre-employment

Print Screening Results Here or Affix with Tamper Evident Tape

STEP 2: TO BE COMPLETED BY EMPLOYEE

I certify that I am about to submit to alcohol testing required by US Department of Transportation regulations and that the identifying information provided on the form is true and correct.

 Signature of Employee Date Month Day Year

Print Confirmation Results Here or Affix with Tamper Evident Tape

STEP 3: TO BE COMPLETED BY ALCOHOL TECHNICIAN

(If the technician conducting the screening test is not the same technician who will be conducting the confirmation test, each technician must complete their own form.) I certify that I have conducted alcohol testing on the above named individual in accordance with the procedures established in the US Department of Transportation regulation, 49 CFR Part 40, that I am qualified to operate the testing device(s) identified, and that the results are as recorded.

TECHNICIAN: BAT STT DEVICE: SALIVA BREATH* 15 Minute Wait: Yes No

SCREENING TEST: *(For BREATH DEVICE* write in the space below only if the testing device is not designed to print.)*

Test #	Testing Device Name	Device Serial # <u>OR</u> Lot # & Exp Date	Activation Time	Reading Time	Result

CONFIRMATION TEST: Results **MUST** be affixed to each copy of this form or printed directly onto the form.

REMARKS:

Alcohol Technician's Company _____ Company Street Address _____
(PRINT) Alcohol Technician's Name (First, M.I., Last) Company City, State, Zip _____ Phone Number _____
()

Signature of Alcohol Technician _____ Date Month Day Year _____

Print Additional Results Here or Affix With Tamper Evident Tape

STEP 4: TO BE COMPLETED BY EMPLOYEE IF TEST RESULT IS 0.02 OR HIGHER

I certify that I have submitted to the alcohol test, the results of which are accurately recorded on this form. I understand that I must not drive, perform safety-sensitive duties, or operate heavy equipment because the results are 0.02 or greater.

 Signature of Employee Date Month Day Year

COPY 1 – ORIGINAL – FORWARD TO THE EMPLOYER

**Federal Drug Testing Custody and Control Form (CCF)
and/or
U.S. Department of Transportation Alcohol Testing Form (ATF)
Suppliers**

*****The following list is being provided as potential sources for purchasing the Federal Drug Testing Custody and Control Form and/or U.S. Department of Transportation Alcohol Testing Form. The Department of Transportation is providing this information as a courtesy and does not consider this an endorsement of any company. Therefore, you may wish to consider other available sources.

Alpha Pro Solutions, Inc. ~ ATF only

735 Arlington Ave North, Ste. 104
St. Petersburg, FL 33701
Phone: 800-277-1997
Fax: 775-871-8538
www.alphaprosolutions.com

Atlantic Business Forms Inc. ~ CCF only

1520 Ednam Forrest Drive
Richmond, VA 23233
Phone: 804-741-0537
Fax: 804-741-0538

CMI, Inc. ~ ATF only

316 East Ninth Street
Owensboro, KY 42303
Phone: 866-835-0690
Fax: 270-685-6268
Contact: Customer Service
www.alcoholtest.com

Draeger Safety Diagnostics, Inc. ~ ATF only

4040 W. Royal Ln, Ste 136
Irving, TX 75063
Phone: 866-385-5900
Fax: 972-929-1260
info@dsvdi.biz

Intoximeters, Inc. ~ ATF only

8110 Lackland Road
St. Louis, MO 63114
Phone: 800-451-8639
Fax: 314-429-4170
Contact: Customer Service
www.intox.com

J. J. Keller & Associates, Inc. ~ CCF & ATF

3003 Breezewood Lane
Neenah, WI 54957
Phone: 800-327-6868
Fax: 800-727-7516
www.jjkeller.com

Khantact USA, Inc. ~ ATF only

37 N. Hillside Ave.
Hillside, IL 60162
Phone: 800-742-4909
Fax: 708-449-7832
www.kahntactusa.com

LAB Documents ~ CCF & ATF

1911 Vernon
North Kansas City, MO 64116
Phone: 816-584-9033
Fax: 816-584-9034
Contact: mmaddox@mindspring.com

Lifeloc Technologies, Inc. ~ ATF only

12441 W. 49th Ave., Ste. 4
Wheat Ridge, CO 80033
Phone: 800-722-4872
Fax: 303-431-1423
info@lifeloc.com

Section 2

Commercial Driver's License Standards, Requirements, And Penalties

(49 CFR, Part 383)

PURPOSE of 49 CFR, Part 383: to help reduce or prevent commercial vehicle accidents, fatalities, and injuries by:

- Requiring that no driver has more than one driver's license.
- Disqualifying drivers who have committed certain serious traffic violations, or other specified offenses.
- Strengthening licensing and testing standards.

Commercial Driver's License Information System (CDLIS): The CDLIS enables the States to exchange information about the driving records and driver's licenses of commercial vehicle drivers. This helps assure that only one license is issued to a driver and that disqualified drivers are prevented from obtaining a CDL. Employers may obtain an abstract of driving records from the Washington State Department of Licensing.

A COMMERCIAL DRIVER'S LICENSE (CDL) IS REQUIRED TO OPERATE ANY OF THE FOLLOWING VEHICLES:

CDL CLASS A: Any combination of vehicles with a gross combination weight rating (GCWR) of 26,001 pounds or more provided the GVWR of the vehicle(s) being towed is in excess of 10,000 pounds.

CDL CLASS B: Any single vehicle with a GVWR of 26,001 pounds or more, or any such vehicle towing a vehicle not in excess of 10,000 pounds GVWR.

CDL CLASS C: Any single vehicle, or combination of vehicles, that meets neither the definition of Group A nor that of Group B as contained in this section, but that either is designed to transport 16 or more passengers including the driver, or is used in the transportation of hazardous materials as defined in § 383.5.

ENDORSEMENTS/RESTRICTIONS:

ENDORSEMENT P:	Passenger Endorsement (Required for drivers of passenger vehicles designed to carry 16 or more passengers including the driver and school buses.)
ENDORSEMENT S:	School Bus Endorsement
ENDORSEMENT H:	Placarded hazardous materials
ENDORSEMENT N:	Tank vehicles (Liquids/Gases)
ENDORSEMENT T:	Double and triple trailer combination unit
ENDORSEMENT X:	Both tank vehicles and placarded hazardous materials
RESTRICTION L:	Non-air brake commercial vehicles only
RESTRICTION Z:	No full air brake equipped commercial motor vehicles
RESTRICTION E:	No manual transmission equipped commercial motor vehicles
RESTRICTION O:	No tractor-trailer commercial motor vehicles
RESTRICTION M:	No Class A passenger vehicles
RESTRICTION N:	No Class A and B passenger vehicles
RESTRICTION K:	Declared intrastate only CDL driver
RESTRICTION V:	Medical Variance

***Air Brake Restrictions:** If an applicant fails the air brake section of the knowledge test, or performs the skills test in a vehicle not equipped with air brakes, the applicant's CDL, if issued, will indicate the license holder may not operate any commercial vehicle equipped with air brakes.

DRIVERS EXEMPT FROM HAVING TO OBTAIN A CDL.

1. Farmers transporting farm equipment, supplies or products to or from a farm -- in a farm vehicle -- are exempt provided:
 - The vehicle is not used in the operation of for-hire motor carriage.
 - The vehicle is used within 150 miles of the farm.
2. Fire fighters and law enforcement officers operating emergency equipment are exempt provided:
 - They have completed the Emergency Vehicle Accident Prevention Program (EVAP).
 - They carry a card certifying completion.
3. Recreation Vehicle Operators are exempt when driving RV's for non-commercial purposes. This includes horse trailers and 2-axle rental trucks for non-commercial use.
4. Active duty military personnel who operate commercial motor vehicles for military purposes.

49 CFR, Part 383 contains the following provisions:

- A commercial driver cannot have more than one driver's license.
- A commercial driver seeking an endorsement must pass a written test and a skill test to qualify for a commercial driver's license.
- A commercial driver seeking endorsements for hazardous materials will be required to have a background check under provisions of the USA PATRIOT ACT of 2001. A driver with a current hazardous materials endorsement will be required to have a background check before renewal of the license endorsement.
- A driver must notify his/her employer of all traffic convictions committed while operating a commercial vehicle. Notification must be in writing within 30 days of the conviction.
- A driver must notify his/her employer of suspended, canceled, revoked licenses, or disqualification from driving a commercial motor vehicle (CMV) by the end of the business day following the day the employee received notice.
- A driver must give 10 years previous employment information when applying for employment as an operator of a commercial motor vehicle.
- An employer may not allow a person to operate a commercial motor vehicle if:
 - › Driver's license is suspended, revoked or canceled.
 - › Driver is disqualified from driving.
 - › Driver has more than one driver's license.

***Beginning January 1, 2021, CDL drivers who self-certify as non-excepted interstate, excepted interstate or non-excepted intrastate must provide a current copy of a medical examiner's certificate prepared by a medical examiner, to the Department of Licensing. (RCW 46.25.075)**

Note: See chart on the following page to determine if you need a CDL.

DO YOU NEED A COMMERCIAL DRIVER'S LICENSE?

There are three types of Commercial Driver's Licenses, Class "A," Class "B," and Class "C."
 To see if you need a Commercial Driver's License, answer the questions and follow the arrows:

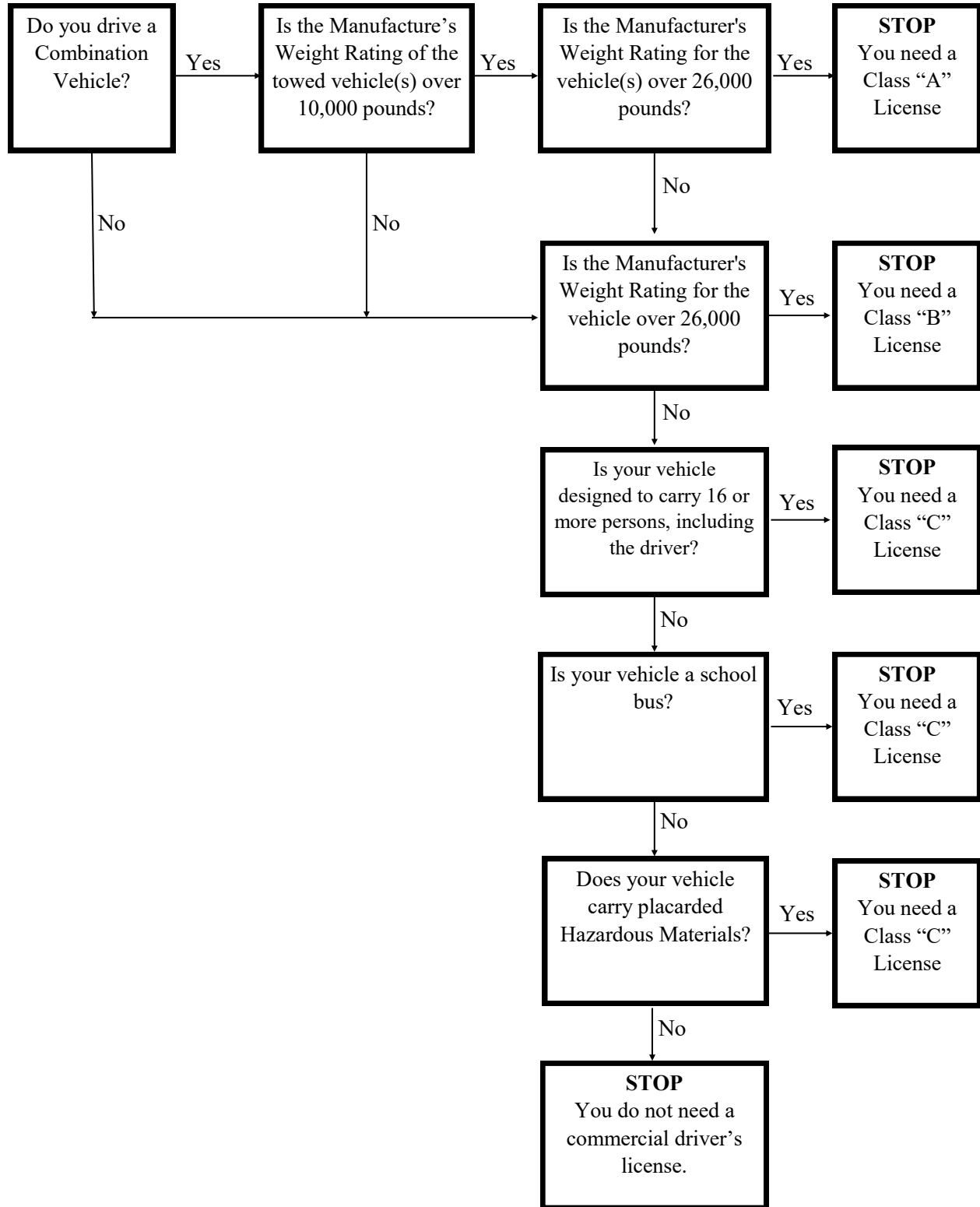

Self-Certify Options:		
Type of Certification and Status	Self-certify as this type if you...	Medical Documents
<p>Non-excepted interstate commercial driver</p> <p>Status:</p> <ul style="list-style-type: none"> • Self-certification: Non-excepted interstate • Medical certification: Certified 	<ul style="list-style-type: none"> • Cross state lines driving a commercial vehicle. • Transport cargo that is not from Washington or is leaving Washington. • Deliver cargo to Washington ports. • School bus drivers with passengers crossing state lines to events. • Delivering goods across state lines. • Delivering goods, including logs, to Washington ports. 	<p>Medical Examiners Certificate – kept on file with us and carried by you when you are driving a commercial vehicle in Washington.</p> <p>Other Documents: If you have a disqualifying medical condition, submit a current Federal Exemption and/or SPE form.</p>
<p>Excepted interstate commercial driver</p> <p>Status</p> <ul style="list-style-type: none"> • Self-certification Excepted interstate • Medical certification <ul style="list-style-type: none"> ○ No waiver requirements No status ○ With waiver requirements Certified 	<ul style="list-style-type: none"> • School bus drivers with students crossing state lines to and from school. • Occasionally transport personal property without compensation. • Operate a government vehicle or emergency response vehicle. • Make emergency deliveries of propane or home heating oil. • Drivers crossing state lines for city, county, or state-owned and operated transit organizations. • Truck drivers employed by federal, state or local government to haul or deliver mail, supplies, or other goods. 	<p>Medical Examiners Certificate – carried by you when you're driving a commercial vehicle in Washington.</p> <p>Other documents: If you are required to have an interstate medical waiver, it must be valid and you must carry it when you are driving in Washington.</p>
<p>Non-excepted intrastate driver</p> <p>Status</p> <ul style="list-style-type: none"> • Self-certification Non-excepted intrastate • Medical certification <ul style="list-style-type: none"> ○ No waiver requirements: No status ○ With waiver requirements: Certified <p>Note: This is the only intrastate certificate available in Washington. You can not self-certify as an "Excepted intrastate driver."</p>	<ul style="list-style-type: none"> • Do not cross state lines while operating a commercial vehicle. • Transport cargo that originated in and stays in Washington. • School bus drivers who only transport passengers within Washington. • Truck drivers who only transport and deliver goods to and from Washington addresses. 	<p>Medical Examiners Certificate – carried by you when you are driving a commercial vehicle in Washington.</p> <p>Other documents: If you are required to have an intrastate medical waiver, it must be valid and you must carry it when you are driving a commercial vehicle.</p>

DRIVERS CAN BE DISQUALIFIED OR LOSE HIS/HER COMMERCIAL DRIVER'S LICENSES FOR CERTAIN CONVICTIONS.

60-day and 120-day disqualifications:

If convicted on a railroad highway grade crossing violation, 60 days for first violation, 120 days for second violation within any three-year period.

If convicted on two serious traffic violations within 3 years, a driver may lose his/her license for 60 days. A third conviction within 3 years results in a 120-day disqualification.

Serious violations include the following:

1. Excessive speed (15 MPH or more over posted speed limit).
2. Reckless driving (RCW 46.61.500).
3. Negligent driving (RCW 46.61.525).
4. Following too close (RCW 46.61.145).
5. Improper/erratic lane changes.
 - Overtaking on the right (RCW 46.61.115).
 - Limitations on overtaking on the left (RCW 46.61.120).
 - Limitations on driving to the left of the center of the roadway (RCW 46.61.125).

180 days to two year's disqualifications:

A driver is disqualified for at least 180 days, up to two years, for the following convictions:

- Violation of an out-of-service order while transporting hazardous materials requiring placards.
- Violation of an out-of-service order while operating a bus designed to carry 16 or more passengers.

One year disqualifications:

A driver is disqualified for not less than one year for a first-time conviction on the following offenses:

- Driving under the influence of alcohol or any drugs;
- Driving with an alcohol concentration of .04 or more;
- Leaving the scene of an accident;
- Using a commercial vehicle in the commission of a felony;
- Refusing to take a blood-alcohol test; or
- A third conviction on railroad grade crossing violation within three year

NOTE: This publication not intended for sale.

Three year disqualifications:**A driver is disqualified for at least three years:**

- If convicted of any of the above-listed one-year offenses while transporting hazardous materials;
- A second conviction in a period of 10 years on a violation of an out-of-service order involving transportation of placarded hazardous materials or a bus designed for 16 or more passengers.

Lifetime disqualifications:

A person may be disqualified from driving a commercial motor vehicle for life for the following:

- A second conviction for any of the above-listed offenses. (The second conviction may be for the same or a different offense.)
- For using a commercial motor vehicle in the commission of a felony involving the manufacture, distribution, or dispensing of a controlled substance, or possession with intent to manufacture, distribute, or dispense a controlled substance.
- Three or more disqualifications within 5 years for confirmed positive drug or alcohol test under 49 CFR Part 382 and 49 CFR Part 40.

Notification to employer and licensing State required: Upon conviction for any State or local traffic violation, drivers must notify the Department of Licensing (except for parking infractions) and must notify their employer(s) within 30 days. This notification must include the following information:

- Driver's full name.
- Driver's license number.
- Date of conviction.
- Details about the offense, including any resulting suspension, revocation, or cancellation of driving privileges.
- Indication of whether the violation happened in a commercial motor vehicle.
- Location of offense.
- Driver's signature.

Notification to employer of driver's license suspensions: Drivers must provide their employer(s) notice by the end of the business day following the day the driver is informed of suspension, inactivation, revocation, cancellation, disqualification, or loss of the right to operate a commercial motor vehicle for any period of time.

For further guidance concerning Washington State Commercial Driver Licenses, contact:

Driver Examining
Department of Licensing
P O Box 9030
Olympia, WA 98504-9030
Telephone: (360) 902-3859

Section 3

Qualifications Of Drivers

(49 CFR, Part 391)

Drivers must be qualified to operate commercial vehicles. Part 391 explains what a carrier must do to qualify drivers.

Generally, a commercial motor vehicle driver must meet the following requirements:

- Be in good health.
- Be at least 18 years of age (if operating exclusively in Washington intrastate commerce). Drivers operating in interstate commerce must be at least 21 years of age.
- Speak and read English well enough to converse with the general public, understand highway traffic signs and signals, do his/her job, respond to official questions, and make legible entries on reports and records.
- Be able to drive the vehicle safely.
- Be able to determine whether the vehicle is safely loaded.
- Know how to block, brace, and tie down cargo.
- Have only one valid commercial driver's license.
- Not be disqualified to drive a commercial motor vehicle.
- Provide an employing motor carrier with a list of all motor vehicle violations or a signed statement that the driver has not been convicted of any motor vehicle violations during the past 12 months. A disqualified driver must not be allowed to drive a commercial motor vehicle for any reason.
- Pass a driver's road test.
- Test negatively for controlled substances.
- Complete an application for employment.

PHYSICAL QUALIFICATIONS AND EXAMINATIONS

All drivers of commercial vehicles must pass a physical examination. If the driver passes the physical, the doctor will give the driver a medical examiner's certificate that must be carried at all times when driving a commercial vehicle. The certificate must be renewed every 2 years, or sooner if instructed by the medical examiner.

MEDICAL CERTIFICATE REQUIREMENTS CFR PART 391.41

A person subject to this part must not operate a commercial motor vehicle unless he or she is medically certified as physically qualified to do so, and, when on-duty has on his or her person the original, or a copy, of a current medical examiner's certificate that he or she is physically qualified to drive a commercial motor vehicle. Drivers are required to obtain their FMCSA medical examination from a **certified medical examiner that is listed on the National Registry**.

To find a list of certified medical examiners in your area, go to the National Registry website at <https://nationalregistry.fmcsa.dot.gov>.

Enter the City, State or ZIP Code to find an examiner. You can also use the Advanced Search option to look up a medical examiner by specific search criteria.

CDL exception. A driver required to have a commercial driver's license or a commercial learner's permit under 49 CFR part 383, and who has a current medical examiner's certificate documenting that he or she meets the physical qualification requirements of this part, no longer needs to carry on his or her person the medical examiner's certificate specified at § 391.43(h).

This exception does not apply to non-CDL drivers operating a non-CDL commercial motor vehicle or to CDL drivers that have self-certified as intrastate only and have a "U" restriction on their CDL.

<http://www.dol.wa.gov/about/videos.php?v=YbrsmPh2Eeo>

Part 391.43 contains instructions for performing and recording physical examinations. The primary physical requirements are:

- Drivers must have good eyesight. Glasses or contact lenses are permitted.
- Drivers must hear well. Hearing aids are permitted.
- Drivers must not use nor be addicted to amphetamines, narcotics, or other drugs that may keep the driver from driving safely.
- Drivers cannot be clinically diagnosed as an alcoholic.

NOTE: Drivers who operate for carriers regulated by the Utilities and Transportation Commission may have additional requirements regarding medical certification and driver qualifications. Those requirements should be reviewed by checking the applicable Washington Administrative Code (WAC).

Common diseases or health problems that may keep a driver from passing the physical are:

- Chronic high blood pressure.
- Diabetes, if controlled by insulin.
- Breathing problems such as asthma and emphysema.
- Disqualifying heart disease.
- Impairment of normal body movements.
- Sickness that could cause fainting or “blackout.”
- Mental or nervous problems.

Information Regarding Application for INTRASTATE Medical Waivers:

There are provisions for waiver or disqualification for certain physical defects if the individual is otherwise qualified to drive. If a driver has lost or cannot use a foot, leg, hand, finger(s), or an arm, he/she cannot drive until a waiver is obtained.

The policy described below applies to commercial motor vehicle drivers who carry a Commercial Driver’s License (CDL) but are not physically qualified to drive under the medical requirements of the Federal Motor Carrier Safety Regulations.

Procedure: Providing the driver is otherwise qualified to operate a commercial motor vehicle, a letter of application for a waiver must be submitted jointly by the person who seeks a waiver of the physical disqualification (driver applicant) and by the motor carrier that will employ the driver applicant. (If the driver is self-employed or currently unemployed, a letter from the motor carrier is not necessary.)

The letter must show:

- Name and complete address of the employing motor carrier.
- Name, license number and complete address of the driver applicant.
- Description of the driver applicant’s impairment for which the waiver is requested.

The letter must be accompanied by:

- A copy of the DOT physical form (long form) showing the results of the medical examination.
- A medical evaluation summary completed by either a board qualified or board certified physician or orthopedic surgeon.

The medical evaluation summary must include:

- A statement by the doctor on how and why the impairment interferes with the ability of the driver to perform normal tasks associated with operating a commercial motor vehicle.
- An assessment and medical opinion of whether the condition will likely remain medically stable for at least two years.

MEDICAL ADVISORY CRITERIA SYNOPSIS

1. No loss of a foot, leg, hand or arm.
2. No impairment of a hand, finger, arm, foot, or leg, which interferes with the ability to perform normal tasks.
3. No clinical diagnosis or medical history of diabetes mellitus requiring insulin.
4. No clinical diagnosis of myocardial infarction, angina pectoris, coronary insufficiency, thrombosis or cardiovascular disease known to be accompanied by syncope, dyspnea, collapse, or congestive cardiac failure.
5. No clinical diagnosis of respiratory dysfunction.
6. No clinical diagnosis of high blood pressure.
7. No clinical diagnosis of rheumatic, arthritic, orthopedic, muscular, neuromuscular or vascular disease which interferes with the ability to control and operate a motor vehicle.
8. No established medical history or clinical diagnosis of epilepsy.
9. No mental, nervous, organic or functional disease or psychiatric disorder likely to interfere with the ability to operate a motor vehicle.
10. Distant visual acuity of at least 20/40 (Snellen) in each eye with or without corrective lenses.
11. Adequate hearing ability.
12. Does not use a controlled substance.
13. No current diagnosis of alcoholism.

Self-Certify Options:		
Type of Certification and Status	Self-certify as this type if you...	Medical Documents
<p>Non-excepted interstate commercial driver</p> <p>Status:</p> <ul style="list-style-type: none"> • Self-certification: Non-excepted interstate • Medical certification: Certified 	<ul style="list-style-type: none"> • Cross state lines driving a commercial vehicle. • Transport cargo that is not from Washington or is leaving Washington. • Deliver cargo to Washington ports. • School bus drivers with passengers crossing state lines to events. • Delivering goods across state lines. • Delivering goods, including logs, to Washington ports. 	<p>Medical Examiners Certificate – kept on file with us and carried by you when you are driving a commercial vehicle in Washington.</p> <p>Other Documents: If you have a disqualifying medical condition, submit a current Federal Exemption and/or SPE form.</p>
<p>Excepted interstate commercial driver</p> <p>Status</p> <ul style="list-style-type: none"> • Self-certification Excepted interstate • Medical certification <ul style="list-style-type: none"> ○ No waiver requirements No status ○ With waiver requirements Certified 	<ul style="list-style-type: none"> • School bus drivers with students crossing state lines to and from school. • Occasionally transport personal property without compensation. • Operate a government vehicle or emergency response vehicle. • Make emergency deliveries of propane or home heating oil. • Drivers crossing state lines for city, county, or state-owned and operated transit organizations. • Truck drivers employed by federal, state or local government to haul or deliver mail, supplies, or other goods. 	<p>Medical Examiners Certificate – carried by you when you’re driving a commercial vehicle in Washington.</p> <p>Other documents: If you are required to have an interstate medical waiver, it must be valid and you must carry it when you are driving in Washington.</p>
<p>Non-excepted intrastate driver</p> <p>Status</p> <ul style="list-style-type: none"> • Self-certification Non-excepted intrastate • Medical certification <ul style="list-style-type: none"> ○ No waiver requirements: No status ○ With waiver requirements: Certified <p>Note: This is the only intrastate certificate available in Washington. You can not self-certify as an “Excepted intrastate driver.”</p>	<ul style="list-style-type: none"> • Do not cross state lines while operating a commercial vehicle. • Transport cargo that originated in and stays in Washington. • School bus drivers who only transport passengers within Washington. • Truck drivers who only transport and deliver goods to and from Washington addresses. 	<p>Medical Examiners Certificate – carried by you when you are driving a commercial vehicle in Washington.</p> <p>Other documents: If you are required to have an intrastate medical waiver, it must be valid and you must carry it when you are driving a commercial vehicle.</p>

Please Note: Department of Licensing issues waivers only for CDL drivers -- they do not issue waivers for non-CDL drivers.

INTRASTATE NON-CDL PASSENGER VEHICLE DRIVERS

WAC 480-30-226(2) & (3)

(1) **Doctor's statement of intrastate medical waiver.** A passenger transportation company may employ a driver that is not physically qualified to drive a commercial motor vehicle under Title 49 C.F.R. Part 391.41, if the driver:

- (a) Holds a valid Washington state driver's license;
- (b) Has received a doctor's statement that:
 - (i) The driver's medical condition is not likely to interfere with the driver's ability to safely operate a commercial motor vehicle; and
 - (ii) The doctor's opinion is that the driver's condition is likely to remain stable for the two years that the medical certificate is valid.
- (c) Operates commercial motor vehicles intrastate wholly within the state of Washington. For the purposes of a doctor's statement of intrastate medical waiver, a commercial motor vehicle means a motor vehicle:
 - (i) With a gross vehicle weight rating under 26,001 lbs.,
 - (ii) Transporting fifteen or fewer passengers, including the driver, or
 - (iii) With a manufacturer's seating capacity of fifteen or fewer passengers, including the driver.

(2) **Driver qualification files.** A passenger transportation company that employs a driver under an intrastate medical waiver must maintain in the driver's qualification file a copy of the doctor's statement of intrastate medical waiver.

For more information contact:

Department of Licensing
CDL Medical Waiver Program
P O Box 9030
Olympia, WA 98507
Telephone: (360) 902-3859
FAX: (360) 586-8351

Multiple-employer drivers: (A driver who in any period of 7 consecutive days is employed or used as a driver by more than a single motor carrier.) The items that must be in a driver qualification file for a multiple-employer driver are the same as those for a regularly employed driver, except the file need not contain:

- An application for employment.
- Inquiries to past employers and state agencies.
- Annual review of driving record.
- Written record of violations.

The carrier must have on file the following information for multiple-employer drivers:

- Driver's name.
- Social Security Number.
- Motor vehicle operator's license.
- Road test and certificate.
- Controlled substance test results.

Drivers furnished by other motor carriers. A motor carrier using a driver regularly employed by another motor carrier must have on file a signed written certificate that includes the following information:

- Driver's name and signature.
- Certification of the driver's full qualifications.
- Expiration date of the driver's medical certificate.
- Compliance with drug and alcohol testing requirements.

The following records may be removed from the driver's qualification file, three (3) years after the date of execution:

- Response of each State agency to the annual driver record inquiry.
- Note relating to annual review of the driver's driving record.
- List or certificate relating to violations of motor vehicle laws.
- Medical examiner's certificate.
- Letter granting a waiver of a physical disqualification.

DRIVER INVESTIGATIVE HISTORY FILE (DIHF) (391.53)

1. Carrier is required to obtain and review prospective driver's safety performance history as a commercial motor vehicle driver.
2. Information contained in this file must be kept in a secured location with limited access.
3. DIHF does not have to be kept on those drivers not hired.
4. Applies to drivers hired after October 29th, 2004.
5. The DIHF must contain, as a minimum, the following information:
 - Copy of the driver's written authorization for the motor carrier to seek information about a driver's alcohol and controlled substance history.
 - A copy of the responses received for investigations into:
 - General driver identification and employment verification, including previous employer's name and address, date of contact, and information received.
 - Accident Information for the previous three years.
 - Part B violations of Part 382/Part 40.
 - Whether a driver failed to undertake or complete a rehabilitation program prescribed by a SAP.
 - Violations occurring after completion of a referral program.
 - Documentation of failures to contact a previous employer, or of the previous employer's failure to provide the required safety performance history.

Previous Employer's Response:

1. Must respond within 30 days after receiving the request.
2. Required to send a response confirming the non-existence of any safety performance history.
3. Provide contact information for any rebuttal.
4. Keep a record of each request for one year, including date, party to whom it was released, and a summary of what was provided.

DUE PROCESS RIGHTS

The driver applicant has the right to:

- Review the information provided by the previous employer(s).
- Have errors in the information corrected by the previous employer(s) and have that corrected information sent to the prospective employer.
- Have a rebuttal statement attached to the alleged erroneous information.

DRIVER QUALIFICATION FILE CHECKLIST 391.51

1. ____ Driver's Application for Employment - A person will not be allowed to drive a commercial motor vehicle unless he/she has completed and signed an application for employment. NOTE: The application form must, as a minimum, contain the information in 391.21(b).	49 CFR, 391.21
2. ____ Driver Investigative History File **- Documentation required by CFR Part 391.23 regarding the driver's Safety Performance History. Refer to Page #60	49 CFR, 391.53
3. ____ Inquiry to State Agencies - An investigation into the employee's driving record for the preceding three years. This investigation must be made within 30 days of the date his/her employment begins.	49 CFR, 391.21(a) (1) & (b)
4. ____ Annual Review of Driving Record. At least once every 12 months, a motor carrier must review the driving record of each driver. A note stating the results of this review shall be included in the driver's qualification file. At least once every 12 months, a motor carrier must make an inquiry into the driving record of each driver.	49 CFR, 391.25
5. ____ Annual Driver's Certification of Violations. At least once every 12 months, a motor carrier must require each driver that it employs to prepare and furnish it with a list of all violations of motor vehicle traffic laws and ordinances during the previous 12 months.	49 CFR, 391.27
6. ____ Driver's Road Test and Certificate (or equivalent). A person must not be allowed to drive a commercial motor vehicle until he/she has successfully completed a road test and has been issued a certificate, or a copy of the license or certificate that the motor carrier accepted as equivalent to the driver's road test, pursuant to section 391.33	49 CFR, 391.31 & 33
7. ____ Non-CDL Drivers & Self-Certified Intrastate CDL Drivers. Medical Examiner's Certificate. The driver must pass a medical examination conducted by a certified medical examiner that is listed on the National Registry. A driver must be issued a medical examiner's certificate, which must be carried at all times, and renewed at least every two years. A copy of the medical certificate must be kept in the driver file. ____ CDL Drivers (Interstate Only). Medical Examiner's Certificate. The driver must pass a medical examination conducted by a certified medical examiner that is listed on the National Registry. A valid medical certificate can be used up to 15 days after issuance. After 15 days, the CDLIS motor vehicle record obtained from the current licensing state must be in the driver qualification file.	49 CFR, 391.42 & 45 & 51 See Exception Page 70
8. ____ LCV Certificate of Training or Certificate of Grandfathering. A person must not be allowed to drive a LCV until he/she has been issued a LCV Driver-Training Certificate or a LCV Driver-Training Certificate of Grandfathering.	49 CFR, 380.505 & 380.111
9. ____ Entry-Level Driver-Training Certificate (CDL Driver only). A person must not be allowed to drive a CMV requiring a CDL without first obtaining the required Entry-Level Driver-Training Certificate.	49 CFR, 380.500
10. ____ Medical Examiner Verification. Carriers must maintain in the driver's qualification file a note relating to verification of medical examiner listing on the National Registry of Certified Medical Examiners.	49 CFR, 391.23(m)

***The prospective motor carrier must:**

- Inform the applicant that the information provided on the application concerning previous employers may be used, and the applicant's previous employers will be contacted, for the purpose of investigating the applicant's safety performance history.
- Notify the driver in writing of his/her due process rights (see Due Process Rights in 391.23).

** Records must be maintained in secured location with controlled access.

APPLICATION FOR EMPLOYMENT

COMPANY _____ STREET ADDRESS _____

CITY, STATE AND ZIP CODE _____

APPLICANT'S NAME _____
(First) (Middle) (Maiden Name, if any) (Last)

ADDRESS _____ HOW LONG? _____
(Street) (City) (State and Zip Code)

DATE OF BIRTH _____ PHONE _____ SOCIAL SECURITY NO. _____

PAST ADDRESSES (previous three years)

	STREET	CITY	STATE & ZIP CODE	HOW LONG?
1				
2				
3				
4				

(ATTACH SHEET IF MORE SPACE IS NEEDED)

EXPERIENCE AND QUALIFICATIONS--DRIVER

DRIVER LICENSE	STATE	LICENSE NUMBER	TYPE	EXPIRATION DATE

DRIVING EXPERIENCE

CLASS OF EQUIPMENT	TYPE OF EQUIPMENT (VAN, TANK, FLAT, ETC.)	DATES		APPROX. # OF MILES (TOTAL)
		FROM	TO	
STRAIGHT TRUCK				
TRACTOR/SEMI-TRAILER				
TRACTOR/2 TRAILERS				
OTHER:				

ACCIDENT RECORD FOR PAST 3 YEARS OR MORE (ATTACH SHEET IF MORE SPACE IS NEEDED)

DATES	NATURE OF ACCIDENT (HEAD-ON, REAR-END, UPSET, ETC.)	FATALITIES	INJURIES

(Form 2 Rev. 10-2001)

TRAFFIC CONVICTIONS AND FORFEITURES FOR THE PAST 3 YEARS (OTHER THAN PARKING VIOLATIONS)

LOCATION	DATE	CHARGE	PENALTY

(ATTACH SHEET IF MORE SPACE IS NEEDED)

A. Have you ever been denied a license, permit or privilege to operate a motor vehicle? YES _____ NO _____

B. Has any license, permit, or privilege ever been suspended or revoked? YES _____ NO _____

IF THE ANSWER TO EITHER A OR B IS YES, ATTACH A STATEMENT GIVING FULL DETAILS

EMPLOYMENT RECORD (Attach Sheet if More Space is Needed)

Note: DOT requires that employment for at least 3 years and/or Commercial Driving experience (CDL) for the past 10 years be shown.

LAST EMPLOYER NAME _____

ADDRESS _____

POSITION HELD _____ FROM _____ TO _____ SALARY _____

REASON FOR LEAVING _____

Subject to Federal Motor Carrier Safety Regulations YES _____ NO _____

Performed safety sensitive function subject to DOT Controlled Substance/Alcohol testing YES _____ NO _____

SECOND LAST EMPLOYER NAME _____

ADDRESS _____

POSITION HELD _____ FROM _____ TO _____ SALARY _____

REASON FOR LEAVING _____

Subject to Federal Motor Carrier Safety Regulations: YES _____ NO _____

Performed safety sensitive function subject to DOT Controlled Substance/Alcohol testing YES _____ NO _____

THIRD LAST EMPLOYER NAME _____

ADDRESS _____

POSITION HELD _____ FROM _____ TO _____ SALARY _____

REASON FOR LEAVING _____

Subject to Federal Motor Carrier Safety Regulations: YES _____ NO _____

Performed safety sensitive function subject to DOT Controlled Substance/Alcohol testing YES _____ NO _____

TO BE READ AND SIGNED BY APPLICANT

This certifies that this application was completed by me, and that all entries on it and information in it are true and complete to the best of my knowledge.

(Date)

(Applicant's Signature)

NOTE: A motor carrier may require an applicant to provide information in addition to the information required by the Federal Motor Carrier Safety Regulations.

(Form 2 - Rev. 1-2004)

SAFETY PERFORMANCE HISTORY RECORDS REQUEST

PART 1:	TO BE COMPLETED BY PROSPECTIVE EMPLOYEE
I, (Print Name) _____ _____ First M.I. Last Social Security Number Hereby authorize: _____ _____ Date of Birth Previous Employer: _____ Email: _____ Street: _____ Telephone: _____ City, State, Zip: _____ Fax No.: _____ To release and forward the information requested by section 3 of this document concerning my Alcohol and Controlled Substances Testing records within the previous 3 years from _____ (employment application date) To: Prospective Employer: _____ Attention: _____ Telephone: _____ Street: _____ City, State, Zip: _____ In compliance with §40.25(g) and 391.23(h), release of this information must be made in a written form that ensures confidentiality, such as fax, email, or letter. Prospective employer's fax number: _____ Prospective employer's email address: _____ _____ Applicant's Signature _____ Date This information is being requested in compliance with §40.25(g) and 391.23.	

PART 2:	TO BE COMPLETED BY PREVIOUS EMPLOYER																								
ACCIDENT HISTORY																									
The applicant named above was employed by us. Yes <input type="checkbox"/> No <input type="checkbox"/> Employed as _____ from (m/y) _____ to (m/y) _____ 1. Did he/she drive motor vehicle for you? Yes <input type="checkbox"/> No <input type="checkbox"/> If yes, what type? Straight Truck <input type="checkbox"/> Tractor-Semitrailer <input type="checkbox"/> Bus <input type="checkbox"/> Cargo Tank <input type="checkbox"/> Doubles/Triples <input type="checkbox"/> Other (Specify) _____ 2. Reason for leaving your employ: Discharged <input type="checkbox"/> Resignation <input type="checkbox"/> Lay Off <input type="checkbox"/> Military Duty <input type="checkbox"/> If there is no safety performance history to report, check here <input type="checkbox"/> , sign below and return. ACCIDENTS: Complete the following for any accidents included on your accident register (§390.15(b)) that involved the applicant in the 3 years prior to the application date shown above, or check <input type="checkbox"/> here if there is no accident register data for this driver. <table style="width: 100%; border-collapse: collapse;"> <thead> <tr> <th style="width: 15%;"></th> <th style="width: 15%;">Date</th> <th style="width: 20%;">Location</th> <th style="width: 15%;"># Injuries</th> <th style="width: 15%;"># Fatalities</th> <th style="width: 20%;">Hazmat Spill</th> </tr> </thead> <tbody> <tr> <td>1.</td> <td>_____</td> <td>_____</td> <td>_____</td> <td>_____</td> <td>_____</td> </tr> <tr> <td>2.</td> <td>_____</td> <td>_____</td> <td>_____</td> <td>_____</td> <td>_____</td> </tr> <tr> <td>3.</td> <td>_____</td> <td>_____</td> <td>_____</td> <td>_____</td> <td>_____</td> </tr> </tbody> </table> Please provide information concerning any other accidents involving the applicant that were reported to government agencies or insurers or retained under internal company policies: _____ _____ _____ Any other remarks: _____ _____ _____ Signature: _____ Title: _____ Date: _____			Date	Location	# Injuries	# Fatalities	Hazmat Spill	1.	_____	_____	_____	_____	_____	2.	_____	_____	_____	_____	_____	3.	_____	_____	_____	_____	_____
	Date	Location	# Injuries	# Fatalities	Hazmat Spill																				
1.	_____	_____	_____	_____	_____																				
2.	_____	_____	_____	_____	_____																				
3.	_____	_____	_____	_____	_____																				

PREVIOUS EMPLOYER – COMPLETE PAGE 2 PART 3

PART 3:	TO BE COMPLETED BY PREVIOUS EMPLOYER
DRUG AND ALCOHOL HISTORY	
<p>If driver was not subject to Department of Transportation testing requirements while employed by this employer, please check here <input type="checkbox"/>, fill in the dates of employment from _____ to _____, complete bottom of Part 3, sign, and return.</p> <p>Driver was subject to Department of Transportation testing requirements from _____ to _____.</p>	
<ol style="list-style-type: none"> 1. Has this person had an alcohol test with the result of 0.04 or higher alcohol concentration? YES <input type="checkbox"/> NO <input type="checkbox"/> 2. Has this person tested positive or adulterated or substituted a test specimen for controlled substances? YES <input type="checkbox"/> NO <input type="checkbox"/> 3. Has this person refused to submit to a post-accident, random, reasonable suspicion, or follow-up alcohol or controlled substance test? YES <input type="checkbox"/> NO <input type="checkbox"/> 4. Has this person committed other violations of Subpart B of Part 382, or Part 40? YES <input type="checkbox"/> NO <input type="checkbox"/> 5. If this person has violated a DOT drug and alcohol regulation, did this person complete a SAP-prescribed rehabilitation program in your employ, including return-to-duty and follow-up tests? If yes, please send documentation back with this form. YES <input type="checkbox"/> NO <input type="checkbox"/> 6. For a driver who successfully completed a SAP's rehabilitation referral and remained in your employ, did this driver subsequently have an alcohol test result of 0.04 or greater, a verified positive drug test, or refuse to be tested? YES <input type="checkbox"/> NO <input type="checkbox"/> 	
<p>In answering these questions, include any required DOT drug or alcohol testing information obtained from prior previous employers in the previous 3 years prior to the application date shown on page 1.</p>	
Name: _____	
Company: _____	
Street: _____	
City, State, Zip: _____ Telephone: _____	
Part 3 Completed by (Signature): _____ Date: _____	

PART 4a:	TO BE COMPLETED BY PROSPECTIVE EMPLOYER
<p>This form was (check one) <input type="checkbox"/> Faxed to previous employer <input type="checkbox"/> Mailed <input type="checkbox"/> Emailed <input type="checkbox"/> Other _____</p> <p>By: _____ Date: _____</p>	

PART 4b:	TO BE COMPLETED BY PROSPECTIVE EMPLOYER
<p>Complete below when information is obtained.</p> <p>Information received from: _____</p> <p>Recorded by: _____ Method: <input type="checkbox"/> Fax <input type="checkbox"/> Mail <input type="checkbox"/> Email <input type="checkbox"/> Telephone</p> <p>Date: _____ <input type="checkbox"/> Other _____</p>	

INSTRUCTIONS TO COMPLETE THE SAFETY PERFORMANCE HISTORY RECORDS REQUEST

- PAGE 1 PART 1: Prospective Employee**
 - Complete the information required in this section
 - Sign and date
 - Submit to the Prospective Employer
- PAGE 2 PART 4a: Prospective Employer**
 - Complete the information
 - Send to Previous Employer
- PAGE 1 PART 2: Previous Employer**
 - Complete the information required in this section
 - Sign and date
 - Turn form over to complete SIDE 2 SECTION 3

- PAGE 2 PART 3: Previous Employer**
 - Complete the information required in this section
 - Sign and date
 - Return to Prospective Employer
- PAGE 2 PART 4b: Prospective Employer**
 - Record receipt of the information
 - Retain the form

RECORDS REQUEST FOR DRIVER/APPLICANT SAFETY PERFORMANCE HISTORY

This request is made by the driver/applicant in compliance with the Department of Transportation regulations.

§391.23(i)(2) Drivers who have previous Department of Transportation regulated employment history in the preceding three years, and wish to review previous employer-provided investigative information must submit a written request to the prospective employer, which may be done at any time, including when applying, or as late as thirty (30) days after being employed or being notified of denial of employment. The prospective employer must provide this information to the applicant within five (5) business days of receiving the written request. If the prospective employer has not yet received the requested information from the previous employer(s), then the five-business-days deadline will begin when the prospective employer receives the requested safety-performance history information. If the driver has not arranged to pick up or receive the requested records within thirty (30) days of the prospective employer making them available, the prospective motor carrier may consider the driver to have waived his/her request to review the records.

PART 1:	COMPLETED BY THE DRIVER/APPLICANT
<p>TO:</p> <p>Prospective Employer: _____</p> <p>Street/P.O. Box: _____</p> <p>City, State, Zip: _____ Telephone # _____</p>	
<p>FROM:</p> <p>Driver/Applicant: _____ Social Security/I.D. # _____</p> <p>Street: _____</p> <p>City, State, Zip: _____ Telephone # _____</p>	
<p>I am submitting this written request to obtain copies of my Department of Transportation Safety Performance History for the preceding three years. I understand, for records requested from a prospective employer, that I must arrange to pick up or receive the requested records within thirty (30) days of the records being made available or I have waived my request to review the records.</p>	
<p>This information should be: <input type="checkbox"/> sent to me at the above address.</p> <p style="padding-left: 150px;"><input type="checkbox"/> I will arrange to pick up.</p>	
<p>Driver/Applicant Signature: _____ Date: _____ / _____ / _____</p> <p style="text-align: right; margin-right: 100px;">M D Y</p>	

PART 2:	COMPLETED BY THE PROSPECTIVE EMPLOYER
<p>The information must be provided to the applicant within five (5) business days of receiving the written request. If the prospective employer has not yet received the requested information from the previous employer(s), then the five-business-days deadline will begin when the prospective employer receives the requested safety performance history information.</p>	
<p>Information supplied to:</p>	
<p>Name: _____</p>	
<p>Street: _____</p>	
<p>City, State, Zip: _____</p>	
<p>Comments: _____</p> <p>_____</p> <p>_____</p>	
<p>By:</p> <p>_____ Release Date: _____ / _____ / _____</p> <p style="text-align: right; margin-right: 100px;">M D Y</p> <p style="text-align: center;">Signature/person providing information Telephone #</p>	

COPY 1 PROSPECTIVE EMPLOYER

**SAFETY PERFORMANCE HISTORY INFORMATION
DRIVER/APPLICANT REBUTTAL**

This rebuttal is made by the driver/applicant in compliance with the Department of Transportation regulations.

§391.23(j)(3) Drivers wishing to rebut information in records received pursuant to paragraph (i) of this section must send the rebuttal to the previous employer with instructions to include the rebuttal in that driver's safety performance history.

§391.23(j)(4) After October 29, 2004, within five business days of receiving a rebuttal from a driver, the previous employer must:

- (i) Forward a copy of the rebuttal to the prospective motor carrier employer;
- (ii) Append the rebuttal to the driver's information in the carrier's appropriate file, to be included as part of the response for any subsequent investigating prospective employers for the duration of the three-year data retention requirements.

PART 1: COMPLETED BY THE DRIVER/APPLICANT

TO:
 Previous Employer: _____
 Street/P.O. Box: _____
 City, State, Zip: _____
 Telephone: _____ Fax: _____

FROM:
 Driver/Applicant: _____ Social Security # _____
 Street: _____
 City, State, Zip: _____ Telephone No.: _____

I have submitted this rebuttal to my previous employer requesting that it be attached to my Safety Performance History and provided to subsequent prospective employers.

Reason for the rebuttal (attach documents as necessary): _____

I request that this rebuttal be sent to the attached list of motor carriers.

Driver/Applicant Signature: _____ Date: ____/____/____
M D Y

PART 2: COMPLETED BY THE PREVIOUS EMPLOYER

Received by:
 Signature: _____ Date: ____/____/____
M D Y

COPY 1 PREVIOUS EMPLOYER

**CORRECTION REQUEST
OF
ERRONEOUS SAFETY PERFORMANCE HISTORY INFORMATION**

This request is made by the driver/applicant in compliance with the Department of Transportation regulations, §391.23, investigations and inquiries, paragraphs (j)(1) and (2) as printed below.

§391.23(j)(1) Driver wishing to request correction of erroneous information in records received pursuant to paragraph (j) of this section must send the request for the correction to the previous employer that provided the records to the prospective employer.

§391.23(j)(2) After October 29, 2004, the previous employer must either correct and forward the information to the prospective motor carrier employer, or notify the driver within 15 days of receiving a driver's request to correct the data that it does not agree to correct the data. If the previous employer corrects and forwards the data as requested, that employer must also retain the corrected information as part of the driver's safety performance history record and provide it to subsequent prospective employers when requests for this information are received. If the previous employer corrects the data and forwards it to the prospective motor carrier employer, there is no need to notify the driver.

PART 1:	COMPLETED BY THE DRIVER/APPLICANT
TO:	Prospective Employer: _____ Street/P.O. Box: _____ City, State, Zip: _____ Telephone # _____
FROM:	Driver/Applicant: _____ Social Security/I.D. # _____ Street: _____ City, State, Zip: _____ Telephone # _____
I request correction of erroneous information in my Safety Performance History. Please forward to the following prospective employer: Company Name: _____ Attention: _____ Street: _____ City, State, Zip: _____	
Explanation of desired correction (attach documents as necessary) _____ _____	
Driver/Applicant Signature: _____ Date: ____/____/____ M D Y	
Driver: Retain COPY 4 DRIVER RECORD for your files, Submit copies 1, 2, and 3 to your previous employer.	

PART 2:	COMPLETED BY THE PREVIOUS EMPLOYER
Disposition of the requested information: <input type="checkbox"/> Information was corrected and forwarded to the prospective motor carrier employer. <input type="checkbox"/> The driver was notified on ____/____/____ that the previous employer does not agree to correct the data. Return copy 3 to the driver.	
Information sent to: Company Name: _____ Attention: _____ Street: _____ City, State, Zip: _____	
Comments: _____ _____	
By: _____ Release Date: ____/____/____ Signature/person providing information Telephone # M D Y	

PART 3:	COMPLETED BY THE PROSPECTIVE MOTOR CARRIER EMPLOYER
The corrected information was received on ____/____/____	
Prospective Employer: _____ Location: _____	
Received by: _____ Signature Title	

COPY 1 PROSPECTIVE EMPLOYER

Form MCSA-5876

OMB No. 2126-0006 Expiration Date: 11/30/2021

Public Burden Statement

A Federal agency may not conduct or sponsor, and a person is not required to respond to, a penalty for failure to comply with a collection of information subject to the requirements of the Paperwork Reduction Act unless that collection of information displays a current valid OMB Control Number. The OMB Control Number for this information collection is 2126-0006. Public reporting burden for this collection of information is estimated to average 1 minute per response, including the time for reviewing instructions, gathering the data needed, and completing and reviewing the collection of information. All responses to this collection of information are mandatory. Send comments regarding this burden estimate or any other aspect of this collection of information, including suggestions for reducing this burden to: Information Collection Clearance Office, Federal Motor Carrier Safety Administration, MC-98A, 1200 New Jersey Avenue, SE, Washington, D.C. 20590.



U.S. Department of Transportation
Federal Motor Carrier
Safety Administration

Medical Examiner's Certificate

(for Commercial Driver Medical Certification)

I certify that I have examined **Last Name:** [] **First Name:** [] in accordance with (please check only one):

- the Federal Motor Carrier Safety Regulations (49 CFR 391.41-391.49) and, with knowledge of the driving duties, I find this person is qualified, and, if applicable, only when (check all that apply) **OR**
- the Federal Motor Carrier Safety Regulations (49 CFR 391.41-391.49) with any applicable State variances (which will only be valid for intrastate operations), and, with knowledge of the driving duties, I find this person is qualified, and, if applicable, only when (check all that apply):
 - Wearing corrective lenses Accompanied by a [] waiver/exemption Driving within an exempt intracity zone (49 CFR 391.62) (Federal)
 - Wearing hearing aid Accompanied by a Skill Performance Evaluation (SPE) Certificate Qualified by operation of 49 CFR 391.64 (Federal)
 - Grandfathered from State requirements (State)

The information I have provided regarding this physical examination is true and complete. A complete Medical Examination Report Form, MCSA-5875, with any attachments embodies my findings completely and correctly and is on file in my office.

Medical Examiner's Certificate Expiration Date []

Medical Examiner's Signature [] **Medical Examiner's Telephone Number** [] **Date Certificate Signed** []

Medical Examiner's Name (please print or type) [] MD Physician Assistant Advanced Practice Nurse DO Chiropractor Other Practitioner (specify) []

Medical Examiner's State License, Certificate, or Registration Number [] **Issuing State** [] **National Registry Number** []

Driver's Signature [] **Driver's License Number** [] **Issuing State/Province** []

Driver's Address **Street Address:** [] **City:** [] **State/Province:** [] **Zip Code:** [] **CLP/CDL Applicant/Holder** Yes No

**This document contains sensitive information and is for official use only. Improper handling of this information could negatively affect individuals. Handle and secure this information appropriately to prevent inadvertent disclosure by keeping the documents under the control of authorized persons. Properly dispose of this document when no longer required to be maintained by regulatory requirements. **

DRIVER'S ROAD TEST EXAMINATION

LAST NAME: _____ FIRST NAME: _____ MI: _____ (MAIDEN NAME IF APPLICABLE): _____

ADDRESS: _____

CITY: _____ STATE: _____ ZIP: _____

TELEPHONE: (H) : _____ (CELL) _____ SPE TESTING SITE STATE: _____

The road test shall be given by the motor carrier or a person designated by it. However, a driver who is a motor carrier must be given the test by another person. The test shall be given by a person who is competent to evaluate and determine whether the person who takes the test has demonstrated that he or she is capable of operating the vehicle and associated equipment that the motor carrier intends to assign.

Rating of Performance:

- _____ Pre-trip inspection (As required by Sec. 392.7)
- _____ Coupling and un-coupling of combination units, (if the equipment the driver may drive includes combination units)
- _____ Placing the equipment in operation
- _____ Use of the vehicle's controls and emergency equipment
- _____ Operating the vehicle in traffic and while passing other vehicles.
- _____ Turning the vehicle
- _____ Braking, and slowing the vehicle by means other than braking
- _____ Backing, and parking the vehicle.
- _____ Other, Explain

Type of equipment used in giving test: _____

Date: _____ (DD/MM/YYYY) EXAMINER'S NAME (PRINT) _____

EXAMINER'S NAME (SIGNATURE) _____

If the road test is successfully completed, the person who administered the test will complete a certificate of driver's road test.

Remarks: _____

CERTIFICATE OF DRIVER'S ROAD TEST

Instructions: If the road test is successfully completed, the person who gave it shall complete a Certificate of the driver's road test. The original or copy of the Certificate shall be retained in the employing motor carrier's driver qualification file of the person examined and a copy given to the person who was examined. (49 CFR 391.33(e) (f) (g))

CERTIFICATION OF ROAD TEST

DRIVERS LAST NAME: _____ FIRST NAME: _____ MI: _____

(MAIDEN NAME IF APPLICABLE): _____

Social Security Number _____

Operator's or Chauffeur's License Number: _____

State of Issuance: _____

Type of Power Unit: _____

Type of Trailer(s): _____

If Passenger carrier, type of Bus: _____

This is to certify that the above-named driver completed a road test under my supervision on _____ (DD/MM/YYYY) consisting of approximately: _____ miles of driving.

It is my considered opinion that this driver possesses sufficient driving skill to safely operate the type of commercial motor vehicle listed above.

Examiner's Name (Print): _____

Examiner's Name (Signature): _____

Title: _____

State Test Site: _____

Organization and Address of Examiner: _____

ANNUAL DRIVER'S CERTIFICATION OF VIOLATIONS

MOTOR CARRIER INSTRUCTIONS: Each motor carrier must at least once every 12 months, require each driver to prepare a list of all violations of motor vehicle traffic laws and ordinances (other than violations involving only parking) of which the driver has been convicted, or of which he/she has forfeited bond or collateral during the preceding 12 months (49 CFR 391.27). Drivers who have provided information required by 49 CFR 383.31 need not repeat that information on this form.

DRIVER REQUIREMENTS: Each driver will provide the list as required by the motor carrier above. If the driver has not been convicted of, or forfeited bond or collateral on account of, any violation which must be listed, he/she shall so certify (49 CFR 391.27).

DRIVER NAME: LAST, FIRST, MI	SOCIAL SECURITY NUMBER	DATE OF EMPLOYMENT	
HOME TERMINAL (CITY AND STATE)	DRIVER'S LICENSE NUMBER	STATE	EXPIRATION DATE

COMPLETED BY DRIVER - CERTIFICATION OF VIOLATIONS

I certify that the following is a true and complete list of traffic violations required to be listed (other than those I have provided under 49 CFR 383) for which I have been convicted or forfeited bond or collateral during the past 12 months.

Check this box if you have had no violations in the past 12 months.

DATE	OFFENSE	LOCATION	TYPE OF VEHICLE OPERATED

If no violations are listed above, I certify that I have not been convicted or forfeited bond or collateral on account of any violation required to be listed during the past 12 months.

DATE	DRIVER'S SIGNATURE
------	--------------------

ANNUAL REVIEW OF DRIVING RECORD

MOTOR CARRIER INSTRUCTIONS: Review the driver's motor vehicle record, annual Certification of Violations, and other information described in 49 CFR 391.25 of the Federal Motor Carrier Safety Regulations. Complete information below.

I have reviewed the driving record of the above-named driver in accordance with 49 CFR 391.25 and find that he/she (check one):

- Meets minimum requirements for safe driving
- Is disqualified to drive a motor vehicle pursuant to Section 391.15 Actions taken with driver:

MOTOR CARRIER NAME	MOTOR CARRIER ADDRESS		
REVIEWER PRINTED NAME	REVIEWER SIGNATURE	TITLE	DATE OF REVIEW

MULTIPLE-EMPLOYER DRIVERS

Instructions: If a motor carrier employs a person as a multiple-employer driver (as defined in 49 CFR 390.5), the motor carrier shall comply with all requirements of Part 391, except the carrier need not—

- (1) Require the person to furnish an application for employment (391.21);
- (2) Make an inquiry into the person's driving record during the preceding three years to the appropriate State agency(s) and an investigation of the person's employment record during the preceding three years (391.23);
- (3) Perform annual review of the person's driving record (391.25); or
- (4) Require the person to furnish a record of violations or a certificate (391.27).

The checklist below may be helpful to ensure that required documents are obtained.

DRIVER QUALIFICATION FILE CHECKLIST

Name _____

Social Security Number _____

Driver's License Number _____

Type of License _____ State _____

In addition to the above information, copies of the following must be obtained.

- Medical Examiner's Certificate
- Road Test (or equivalent)
- Certificate of Road Test
- Controlled Substances Test

Certificate of Training for Entry Level Commercial Drivers

Driver's first name, middle initial, last name

I certify that the above named driver has completed the training requirements set forth in the Federal Motor Carrier Safety Regulations for entry level driver training in accordance with 49 CFR 380.503

- Driver Qualification Requirements (49 CFR 391)
- Hours of Service of Drivers (49 CFR 395)
- Driver Wellness
- Whistleblower Protection (29 CFR 1978)

Name of Director of Safety

Certificate Issuance Date

Organization Name

Organization Address

Longer Combination Vehicle (LCV) Driver-Training Certificate of Grandfathering

I certify that _____ has presented evidence of meeting the prerequisites set forth in the Federal Motor Carrier Safety Regulations (49 CFR 380.111) for the substitute for LCV driver training and is qualified to operate the LCVs indicated below:

- | | | |
|--------------------------|--------------------------|--------------------|
| YES | NO | |
| <input type="checkbox"/> | <input type="checkbox"/> | LCV Doubles |
| <input type="checkbox"/> | <input type="checkbox"/> | LCV Triples |

DRIVER NAME (First name, MI, Last name)

Commercial Driver's License Number	STATE
------------------------------------	-------

ADDRESS OF DRIVER (Street Address, City, State, and Zip Code)

FULL NAME OF MOTOR CARRIER	Telephone Number
----------------------------	------------------

ADDRESS OF PRINCIPAL PLACE OF BUSINESS (Street Address, City, State, and Zip Code)

SIGNATURE OF MOTOR CARRIER OFFICIAL	DATE ISSUED
-------------------------------------	-------------

Section 4

Driver Operation

(49 CFR, Part 392)

49 CFR, Part 392 contains 7 subparts describing requirements while driving commercial motor vehicles. A brief summary of each of the subparts follows.

SUBPART A -- GENERAL

Applicability: All carriers and their employees must be instructed in and must obey the rules of this part if responsible for:

- Management, maintenance, operation or driving of commercial motor vehicles.
- Hiring, supervising, training, assigning, or dispatching of drivers.

Driving prohibitions: A driver may not drive if he/she:

- Has consumed an alcoholic beverage within 4 hours of going on duty, while on duty, or while driving. A driver is forbidden to possess an alcoholic beverage while on duty, unless it is a manifested part of the shipment.
- Is under the influence of alcohol, schedule I drugs, narcotics or amphetamines (including pep pills and bennies) or any other substance (including prescription or over the counter drugs) causing the driver to drive unsafely.
- Is ill or fatigued to the point that driving or alertness may be impaired, or the illness, fatigue or any other cause makes it unsafe to begin (or continue) to drive the vehicle.

Schedules to conform with speed limits: No motor carrier shall schedule a run nor permit nor require the operation of any commercial motor vehicle between points in such period of time as would necessitate the commercial motor vehicle being operated at speeds greater than those prescribed by the jurisdictions in or through which the commercial motor vehicle is being operated.

Equipment, inspection and use: No commercial motor vehicle shall be driven unless the driver has satisfied himself/herself that the following parts and accessories are in good working condition:

- Service brakes
- Parking brakes
- Lighting devices and reflectors
- Rear-vision mirror or mirrors
- Horn
- Windshield wipers
- Tires
- Wheels and Rims
- Coupling devices
- Emergency equipment
- Steering mechanism

Cargo securement: No person shall drive a commercial motor vehicle and a motor carrier shall not require or permit a person to drive a commercial motor vehicle unless the vehicle's cargo is properly distributed and secured.

SUBPART A - GENERAL (CONT)

Operating authority required: A motor vehicle providing transportation requiring operating authority must not be operated:

Safety registration required: A commercial motor vehicle providing transportation in interstate commerce must not be operated without a safety registration and an active USDOT number.

SUBPART B -- DRIVING

Railroad grade crossings, stopping required: Generally, buses and vehicles transporting hazardous materials must stop at railroad crossings.

No driver of a commercial motor vehicle shall drive onto a highway-rail crossing without having sufficient space to drive completely through the crossing without stopping.

After stopping within at least 50 feet of, but not closer than 15 feet of a crossing, the driver may drive the vehicle across the tracks in a gear that permits the vehicle to complete the crossing without a change of gear.

Hazardous Conditions: Extreme caution in the operation of a commercial motor vehicle shall be exercised when hazardous conditions, such as those caused by snow, ice, sleet, fog, mist, rain, dust, or smoke, adversely affect visibility or traction. Speed shall be reduced when such conditions exist. If conditions become sufficiently dangerous, the operation of the commercial motor vehicle shall be discontinued and shall not be resumed until the commercial motor vehicle can be safely operated. Whenever compliance with the foregoing provisions of this rule increases hazard to passengers, the commercial motor vehicle may be operated to the nearest point at which the safety of passengers is assured.

Seat belts: Drivers are required to wear their seat belts when operating the vehicle.

SUBPART C -- STOPPED VEHICLES

Unattended commercial motor vehicles: A vehicle stopped upon a highway or shoulder must activate the vehicle's hazard warning flashers at once. The driver must leave the flashers on until warning devices (triangles, reflectors, flares, etc.) are activated. The flashers must again be used while the warning devices are being picked up before the vehicle moves on.

The parking brake should be set and any other steps taken to keep the vehicle from moving before the driver leaves the vehicle unattended.

Placement of warning devices: After making an emergency stop, the driver must set out emergency warning devices as soon as possible; but in any event, within ten minutes. The warning devices must be placed as follows (except where specific rules apply):

1. One warning device must be placed on the traffic side of the vehicle, within 10 feet of in the direction of approaching traffic..
2. A second device must be placed facing approaching traffic approximately 100 feet away in the center of the lane or shoulder where the vehicle is stopped.
3. The third device must be placed about 100 feet away from the others, in the opposite direction from the stopped vehicle, and also one in the center of the lane or shoulder.

SUBPART C - STOPPED VEHICLES (CONT)

Fuses: Flame-producing devices may not be used when certain types of hazardous material are being transported.

Lighted fussee or other flame-producing emergency signal shall not be attached to any part of a commercial motor vehicle.

SUBPART D -- USE OF LIGHTED LAMPS AND REFLECTORS

Lights and reflectors are to be clean and not hidden by cargo, tail board, or other obstructions.

SUBPART F -- FUELING PRECAUTIONS

- A driver or employee may not smoke or expose any open flame near a vehicle being fueled.
- Extra fuel shall be carried only in properly mounted tanks.
- The number of times buses are fueled while carrying passengers shall be minimized.
- A driver shall not fuel with the engine running.

SUBPART G -- PROHIBITED PRACTICES

Unauthorized persons prohibited: Unless specifically authorized in writing to do so by the motor carrier under whose authority the commercial motor vehicle is being operated, no driver shall transport any person on any commercial vehicle other than a bus.

Towing buses: No loaded bus shall be towed or pushed.

Carbon monoxide: No person shall dispatch or drive any commercial motor vehicle or permit any passengers thereon, if:

- An occupant has been affected by carbon monoxide.
- Carbon monoxide has been detected in the interior of the commercial motor vehicle.
- Mechanical condition has been discovered which would be likely to produce a hazard to occupants.

Radar detectors: Federal Motor Carrier Safety Regulations prohibit use of radar detectors, including the following:

- A driver of a commercial vehicle shall not use radar detectors.
- A driver shall not operate any commercial motor vehicle that is equipped with a radar detector.
- Motor carriers shall not require or permit a driver to violate the radar detector provisions.

Cellphone/Texting: Driver is prohibited from using any hand-held device, cellphone or texting while operating a motor vehicle.

SUBPART G -- PROHIBITED PRACTICES (CONT)

Safe Operation, Buses: No person shall drive a bus and a motor carrier shall not require or permit a person to drive a bus unless:

- All standees on the bus are rearward of the standee line or other means prescribed in §393.90 of this subchapter.
- All aisle seats in the bus conform to the requirements of §393.91 of this subchapter; and
- Baggage or freight on the bus is stowed and secured in a manner which assures -
 1. Unrestricted freedom of movement to the driver and his proper operation of the bus;
 2. Unobstructed access to all exits by an occupant of the bus; and
 3. Protection of occupants of the bus against injury resulting from the falling or displacement of articles transported in the bus.

Heater, flame-producing; on commercial motor vehicle in motion: No open flame heater used in the loading or unloading of the commodity transportation shall be in operation while the commercial vehicle is in motion.

Section 5

Insurance Requirements

MINIMUM LEVELS OF FINANCIAL RESPONSIBILITY FOR MOTOR CARRIERS, AUTO TRANSPORTATION COMPANIES (AIRPORTERS and BUSES), PASSENGER CHARTER CARRIERS, AND SOLID WASTE COLLECTION COMPANIES.

Motor carriers of property, for-hire carriers of passengers, and solid waste collection companies must have a minimum amount of liability and property damage insurance.

- A motor carrier is required to have an insurance company file evidence of liability and property damage insurance with the Washington Utilities & Transportation Commission (UTC). The insurance filed must be written by a company authorized to write such insurance in the state of Washington.
- Failure to file and keep insurance in full force and effect shall be cause for dismissal of an application or cancellation of a permit.
- Evidence of insurance shall be submitted on a uniform motor carrier bodily injury and property damage liability certificate of insurance (Form E).

An instruction sheet and example of forms are provided on the following pages of this manual.

MINIMUM LEVELS OF FINANCIAL RESPONSIBILITY FOR MOTOR CARRIERS AND PASSENGER CARRIERS OPERATING IN INTERSTATE COMMERCE.

Those motor carriers of property operating commercial motor vehicles in interstate or foreign commerce must have a minimum amount of insurance as prescribed in 49 CFR, Part 387. Motor carriers operating in interstate commerce must have proof of the minimum level of insurance at the company's principal place of business.

Private carriers operating in Washington intrastate commerce are not required to file insurance with the Washington Utilities and Transportation Commission. They must comply with insurance limit requirements contained in Title 46 RCW.

Proof of insurance for interstate carriers can be any of the following:

- Endorsement(s) for Motor Carrier Policies of Insurance for Public Liability under Sections 29 and 30 of the Motor Carrier Act of 1980 (Form MCS-90) issued by an insurer(s).
- Endorsement(s) for Motor Carrier Policies of Insurance for Public Liability Under Section 18 of the Bus Regulatory Reform Act of 1982 (Form MCS-90B) issued by an insurer(s).
- A Motor Carrier Surety Bond for Public Liability Under Sections 29 and 30 of the Motor Carrier Act of 1980 (Form MCS-82) issued by a surety.
- A Motor Carrier Public Liability Surety Bond Under Section 18 of the Bus Regulatory Reform Act of 1982 (Form MCS 82B) issued by a surety.
- A written decision, order, or authorization of the Interstate Commerce Commission authorizing the motor carrier to self-insure under 49 CFR, Part 1043.5.
- BMC 91X public liability insurance form.

See following chart regarding Schedule of Limits for minimum levels of financial responsibility.



Motor Carrier Insurance Requirements

Licensing Services

360-664-1222

Consumer Help Line

888-333-WUTC (9882)

consumer@utc.wa.gov

TTY

800-416-5289

Education and Outreach

360-664-1110

Media Line

360-664-1116

The UTC regulates the services of privately or investor owned utility and transportation companies. Our mission is to ensure that services are fairly priced, available, reliable and safe.

Regulated companies:

- Telephone
- Electricity
- Natural Gas
- Water
- Garbage
- Recycling
- Residential Movers
- Charter Buses
- Airport Shuttles
- Commercial Ferries
- Natural Gas Pipeline

General Information

360-664-1160

www.utc.wa.gov

PO Box 47250

Olympia WA 98504

If you want to operate as a common carrier, household goods mover, solid waste company, or passenger carrier in the state of Washington you must have a permit or certificate from the Utilities and Transportation Commission (commission) and valid insurance. To apply for a permit or certificate, you must provide proof of liability and property damage insurance. You must also maintain proof of insurance to keep your permit or certificate active.

Form E or Form G - Liability and Property Damage Insurance

Your insurance company must file Form E, Uniform Motor Carrier Bodily Injury and Property Damage Liability Certificate of Insurance. Form E is the standard proof of insurance form issued by insurance companies. You may also file a Form G, Surety Bond, as proof of insurance.

Certificate of Insurance or Binder

We will accept an insurance certificate or binder from your insurance company for a period of **up to 60 days**, but it must be replaced by a Form E **before the 60 days expires**. Insurance certificates or binders must show the UTC as the certificate holder.

Cancellations

Insurance companies must notify the UTC thirty (30) days before your insurance policy expires. If your policy expires, the UTC will suspend your permit or certificate for 30 days. If you do not submit proof of insurance within the 30 days, your permit or certificate will be cancelled. UTC staff will send a letter to notify you if we intend to suspend or cancel your permit or certificate. Prior to canceling your permit or certificate, we will offer you an opportunity for a hearing to explain why we should not cancel your permit or certificate.

Motor Carrier Insurance

Specific requirements for all insurance forms

The UTC will reject insurance forms that do not meet these requirements, which means you will not have valid proof of insurance on file.

- The name on the insurance form **MUST MATCH EXACTLY** the individual, partners, or corporate name on your application for a permit or certificate. It may include a d/b/a or trade name.
- Insurance forms must be received from an insurance company authorized to write insurance in the state of Washington. You may check with the Office of the Insurance Commissioner to determine if your insurance company is authorized in Washington.
- All insurance forms must include:
 - The policy number.
 - The name of the insurance company.
 - The signature of the insurance company's authorized representative.
 - An issue date and effective date.

Cargo Insurance

If you are a household goods carrier, you must maintain proof of cargo insurance at your place of business. For vehicles with a gross vehicle weight of less than 10,000 pounds, you must have \$10,000 minimum levels of cargo insurance. For vehicles 10,000 pounds or more, you must have \$20,000 minimum levels.

For More Information

Licensing Services

(360) 664-1222

Consumer Help Line

888-333-WUTC (9882)

consumer@utc.wa.gov

TTY

800-416-5289

Media Line

360-664-1116

REQUIRED INSURANCE FILING

CARRIERS WITH THIS PERMIT	FOR THESE OPERATIONS OR VEHICLE USAGE	MUST FILE ONE OF THE FOLLOWING FORMS	AT THESE MINIMUM INSURANCE LEVELS
Common Carrier Household Goods	Vehicles under 10,000 GVWR hauling non-hazardous property.	Form E Certificate of Insurance. Form G, Surety Bond. Insurance Binder, good for only 60 days.	\$300,000 Combined Single Limit (CSL)
Common Carrier Household Goods	Vehicles 10,000 GVWR or more hauling non-hazardous property.	Form E Certificate of Insurance. Form G, Surety Bond. Insurance Binder, good for only 60 days.	\$750,000 CSL
Household Goods	Vehicles under 10,000 GVR	Cargo Form H	\$10,000
Household Goods	Vehicles over 10,000 GVR	Cargo Form H	\$20,000
Common Carrier	Vehicles 10,000 GVWR or more hauling: Oil (49 CFR 172.101). Hazardous waste, hazardous materials, and hazardous substances listed in 49 CFR 172.101, but not listed in paragraph above.	Form E Certificate of Insurance. Form G, Surety Bond. Insurance Binder, good for only 60 days.	\$1,000,000 CSL
Common Carrier	Any vehicle hauling: Hazardous substances in bulk, in vehicles with capacities exceeding 3,500 water gallons Explosives A or B in any quantity Poison gas in any quantity Liquefied compressed gas or compressed gas, in bulk in containers exceeding 3,500 water gallons Highway route controlled quantity radio-active materials	Form E Certificate of Insurance. Form G, Surety Bond. Insurance Binder, good for only 60 days.	\$5,000,000 CSL

REQUIRED INSURANCE FILING

CARRIERS WITH THIS PERMIT	FOR THESE OPERATIONS OR VEHICLE USAGE	MUST FILE ONE OF THE FOLLOWING FORMS	AND OBTAIN THESE MINIMUM INSURANCE LEVELS
Solid Waste Collection Companies	Solid waste collection vehicles under 10,000 GVWR.	Form E Certificate of Insurance. Form G, Surety Bond. Insurance Binder, good for only 60 days.	\$300,000 CSL
Solid Waste Collection Companies	Solid waste collection vehicles 10,000 GVWR or more.	Form E Certificate of Insurance. Form G, Surety Bond. Insurance Binder, good for only 60 days.	\$750,000 CSL
Solid Waste Collection Companies	Solid waste collection vehicles that transport quantities of biomedical waste not subject to federal regulation.	Form E Certificate of Insurance. Form G, Surety Bond. Insurance Binder, good for only 60 days.	\$1,000,000 CSL
Passenger carriers	Vehicles with a seating capacity of 15 passengers or less, including the driver.	Form E Certificate of Insurance. Form G, Surety Bond. Insurance Binder, good for only 60 days.	\$1,500,000 CSL
Passenger carriers	Vehicles with a seating capacity of 16 passengers or more, including the driver.	Form E Certificate of Insurance. Form G, Surety Bond. Insurance Binder, good for only 60 days.	\$5,000,000 CSL
Non-profit Special Needs	Vehicles with a seating capacity of 15 passengers or less, including the driver.	Form E Certificate of Insurance. Form G, Surety Bond. Insurance Binder, good for only 60 days.	\$500,000 CSL
Non-profit Special Needs	Vehicles with a seating capacity of 16 passengers or more, including the driver.	Form E Certificate of Insurance. Form G, Surety Bond. Insurance Binder, good for only 60 days.	\$1,000,000 CSL
Rail Contract Crew Carrier	Passenger Vehicles	Form E Certificate of Insurance Form G, Surety Bond, Insurance Binder, good for only 60 days.	\$5,000,000 CSL \$1,000,000 Uninsured and Underinsured Motorist Coverage

Form E

UNIFORM MOTOR CARRIER BODILY INJURY AND PROPERTY
DAMAGE LIABILITY CERTIFICATE OF INSURANCE

(Executed in Triplicate)

Filed with _____ (hereinafter called Commission)
(Name of Commission)

This is to certify that the _____
(Name of Company)

(hereinafter called Company) of _____
(Home Address of Company)

has issued to _____ of _____
(Name of Motor Carrier) (Address of Motor Carrier)

a policy or policies of insurance effective from _____ 12:01 A.M. standard time at the address of the insured stated in said policy or policies and continuing until canceled as provided herein, which, by attachment of the Uniform Motor Carrier Bodily Injury and Property Damage Liability Insurance Endorsement, has or have been amended to provide automobile bodily injury and property damage liability insurance covering the obligations imposed upon such motor carrier by the provisions of the motor carrier law of the State in which the Commission has jurisdiction or regulations promulgated in accordance therewith.

Whenever requested, the Company agrees to furnish the Commission a duplicate original of said policy or policies and all endorsements thereon.

This certificate and the endorsement described herein may not be canceled without cancellation of the policy to which it is attached. Such cancellation may be effected by the Company or the insured giving thirty (30) days' notice in writing to the State Commission, such thirty (30) days' notice to commence and run from the date notice is actually received in the office of the Commission.

Countersigned at _____

this _____ day of _____ 20_____

Authorized Company Representative

Insurance Company File No. _____

FORM MCS-90 Revised 01/05/2017

OMB No.: 2126-0008 Expiration: 01/31/2020

USDOT Number: _____ Date Received: _____

A Federal Agency may not conduct or sponsor, and a person is not required to respond to, nor shall a person be subject to a penalty for failure to comply with a collection of information subject to the requirements of the Paperwork Reduction Act unless that collection of information displays a current valid OMB Control Number. The OMB Control Number for this information collection is 2126-0008. Public reporting for this collection of information is estimated to be approximately 2 minutes per response, including the time for reviewing instructions, gathering the data needed, and completing and reviewing the collection of information. All responses to this collection of information are mandatory. Send comments regarding this burden estimate or any other aspect of this collection of information, including suggestions for reducing this burden to: Information Collection Clearance Officer, Federal Motor Carrier Safety Administration, MC-RRA, Washington, D.C. 20590.



United States Department of Transportation
Federal Motor Carrier Safety Administration

Endorsement for Motor Carrier Policies of Insurance for Public Liability
 under Sections 29 and 30 of the Motor Carrier Act of 1980

FORM MCS-90

Issued to _____ of _____
 (Motor Carrier name) (Motor Carrier state or province)

Dated at _____ on this _____ day of _____,

Amending Policy Number: _____ Effective Date: _____

Name of Insurance Company: _____

Countersigned by: _____
 (authorized company representative)

The policy to which this endorsement is attached provides primary or excess insurance, as indicated for the limits shown (check only one):

- This insurance is primary and the company shall not be liable for amounts in excess of \$ _____ for each accident.
- This insurance is excess and the company shall not be liable for amounts in excess of \$ _____ for each accident in excess of the underlying limit of \$ _____ for each accident.

Whenever required by the Federal Motor Carrier Safety Administration (FMCSA), the company agrees to furnish the FMCSA a duplicate of said policy and all its endorsements. The company also agrees, upon telephone request by an authorized representative of the FMCSA, to verify that the policy is in force as of a particular date. The telephone number to call is: _____.

Cancellation of this endorsement may be effected by the company or the insured by giving (1) thirty-five (35) days notice in writing to the other party (said 35 days notice to commence from the date the notice is mailed, proof of mailing shall be sufficient proof of notice), and (2) if the insured is subject to the FMCSA's registration requirements under [49 U.S.C. 13901](#), by providing thirty (30) days notice to the FMCSA (said 30 days notice to commence from the date the notice is received by the FMCSA at its office in Washington, DC).

(continued on next page)

DEFINITIONS AS USED IN THIS ENDORSEMENT

Accident includes continuous or repeated exposure to conditions or which results in bodily injury, property damage, or environmental damage which the insured neither expected nor intended.

Motor Vehicle means a land vehicle, machine, truck, tractor, trailer, or semitrailer propelled or drawn by mechanical power and used on a highway for transporting property, or any combination thereof.

Bodily Injury means injury to the body, sickness, or disease to any person, including death resulting from any of these.

Property Damage means damage to or loss of use of tangible property.

Environmental Restoration means restitution for the loss, damage, or destruction of natural resources arising out of the accidental discharge, dispersal, release or escape into or upon the land, atmosphere, watercourse, or body of water, of any commodity transported by a motor carrier. This shall include the cost of removal and the cost of necessary measures taken to minimize or mitigate damage to human health, the natural environment, fish, shellfish, and wildlife.

Public Liability means liability for bodily injury, property damage, and environmental restoration.

The insurance policy to which this endorsement is attached provides automobile liability insurance and is amended to assure compliance by the insured, within the limits stated herein, as a motor carrier of property, with Sections 29 and 30 of the Motor Carrier Act of 1980 and the rules and regulations of the Federal Motor Carrier Safety Administration (FMCSA).

In consideration of the premium stated in the policy to which this endorsement is attached, the insurer (the company) agrees to pay, within the limits of liability described herein, any final judgment recovered against the insured for public liability resulting from negligence in the operation, maintenance or use of motor vehicles subject to the financial responsibility requirements of Sections 29 and 30 of the Motor Carrier Act of 1980 regardless of whether or not each motor vehicle is specifically described in the policy and whether or not such negligence occurs on any route or in any territory authorized to be served by the insured or elsewhere. Such insurance as is afforded, for public liability, does not apply to injury to or death of the insured's employees while engaged in the course of their employment, or property transported by the insured, designated as cargo. It is understood and agreed that no condition, provision, stipulation, or limitation contained in the policy, this endorsement, or any other endorsement thereon,

or violation thereof, shall relieve the company from liability or from the payment of any final judgment, within the limits of liability herein described, irrespective of the financial condition, insolvency or bankruptcy of the insured. However, all terms, conditions, and limitations in the policy to which the endorsement is attached shall remain in full force and effect as binding between the insured and the company. The insured agrees to reimburse the company for any payment made by the company on account of any accident, claim, or suit involving a breach of the terms of the policy, and for any payment that the company would not have been obligated to make under the provisions of the policy except for the agreement contained in this endorsement.

It is further understood and agreed that, upon failure of the company to pay any final judgment recovered against the insured as provided herein, the judgment creditor may maintain an action in any court of competent jurisdiction against the company to compel such payment.

The limits of the company's liability for the amounts prescribed in this endorsement apply separately to each accident and any payment under the policy because of anyone accident shall not operate to reduce the liability of the company for the payment of final judgments resulting from any other accident.

(continued on next page)

FORM MCS-90 Revised 01/05/2017

OMB No.: 2126-0008 Expiration: 01/31/2020

SCHEDULE OF LIMITS — PUBLIC LIABILITY
--

Type of carriage	Commodity transported	January 1, 1985
(1) For-hire (in interstate or foreign commerce, with a gross vehicle weight rating of 10,000 or more pounds).	Property (nonhazardous)	\$750,000
(2) For-hire and Private (in interstate, foreign, or intrastate commerce, with a gross vehicle weight rating of 10,000 or more pounds).	Hazardous substances, as defined in 49 CFR 171.8 , transported in cargo tanks, portable tanks, or hopper-type vehicles with capacities in excess of 3,500 water gallons; or in bulk Division 1.1, 1.2, and 1.3 materials, Division 2.3, Hazard Zone A, or Division 6.1, Packing Group I, Hazard Zone A material; in bulk Division 2.1 or 2.2; or highway route controlled quantities of a Class 7 material, as defined in 49 CFR 173.403 .	\$5,000,000
(3) For-hire and Private (in interstate or foreign commerce, in any quantity; or in intrastate commerce, in bulk only; with a gross vehicle weight rating of 10,000 or more pounds).	Oil listed in 49 CFR 172.101 ; hazardous waste, hazardous materials, and hazardous substances defined in 49 CFR 171.8 and listed in 49 CFR 172.101 , but not mentioned in (2) above or (4) below.	\$1,000,000
(4) For-hire and Private (In interstate or foreign commerce, with a gross vehicle weight rating of less than 10,000 pounds).	Any quantity of Division 1.1, 1.2, or 1.3 material; any quantity of a Division 2.3, Hazard Zone A, or Division 6.1, Packing Group I, Hazard Zone A material; or highway route controlled quantities of a Class 7 material as defined in 49 CFR 173.403 .	\$5,000,000

*The schedule of limits shown does not provide coverage. The limits shown in the schedule are for information purposes only.

Section 6

Parts And Accessories Necessary For Safe Operation

(49 CFR, Part 393)

Every motor carrier, its officers, agents, drivers, representatives, and employees involved with the inspection and/or maintenance of equipment must understand and obey the rules of part 393. A carrier cannot operate a commercial motor vehicle unless it is properly equipped.

Parts and accessories shall be in safe and proper operating conditions at all times.

Specific equipment requirements are contained in the following subparts of 49 CFR, Part 393:

SUBPART B - Lighting devices, reflectors and electrical equipment.

SUBPART C - Brakes.

SUBPART D - Glazing and window construction.

SUBPART E - Fuel systems.

SUBPART F - Coupling devices and towing methods.

SUBPART G - Miscellaneous parts and accessories.

SUBPART H - Emergency equipment.

SUBPART I - Protection against shifting or falling cargo.

SUBPART J - Frames, cab and body components, wheels, steering, and suspension systems.

49 CFR 393.89 All passenger-carrying vehicles must comply with this rule per training to drive shaft protection.

RCW 46.37.400 Requires additional mirrors and back-up devices on certain vehicles. You should review this rule to see if it applies to your vehicles.

RCW 46.37.500 Requires motor vehicles and trailers to be equipped with fenders, covers, flaps, or splash aprons adequate for minimizing the spray or splash of water or mud from the roadway to the rear of the vehicle.

Note: This publication not intended for sale.

CONFIGURATION REQUIRMENTS (After 1-26-98)

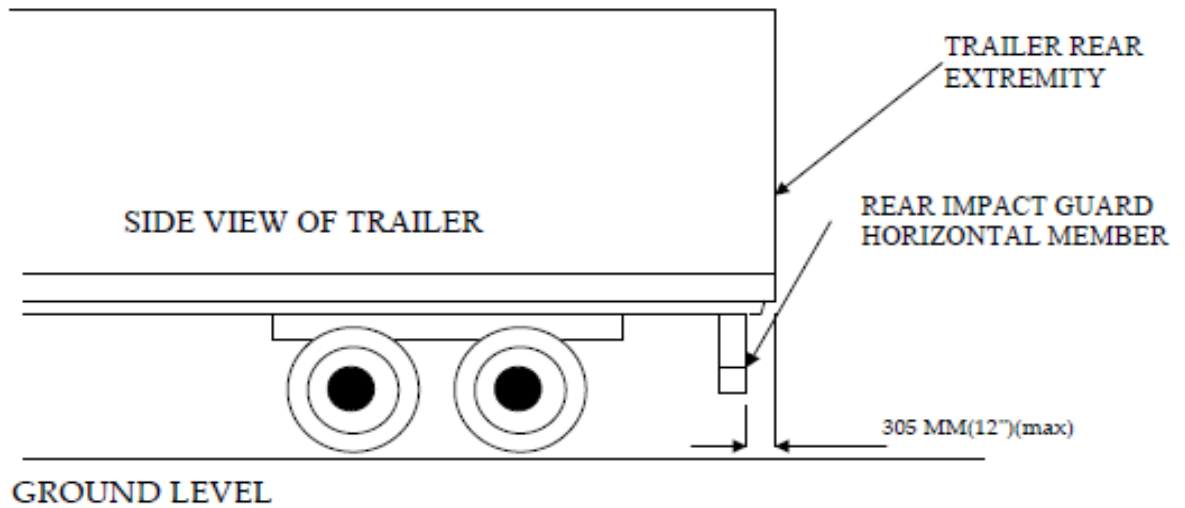
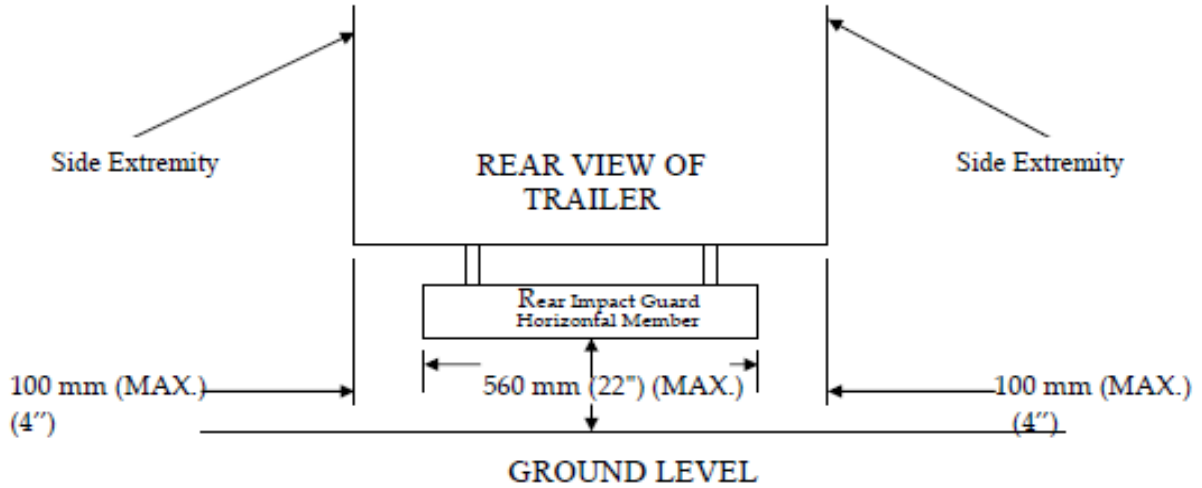

Parts and Accessories Necessary for Safe Operation (49 CFR, Part 393)

REAR END PROTECTION

49 CFR 393.86

(Before 1-26-98)

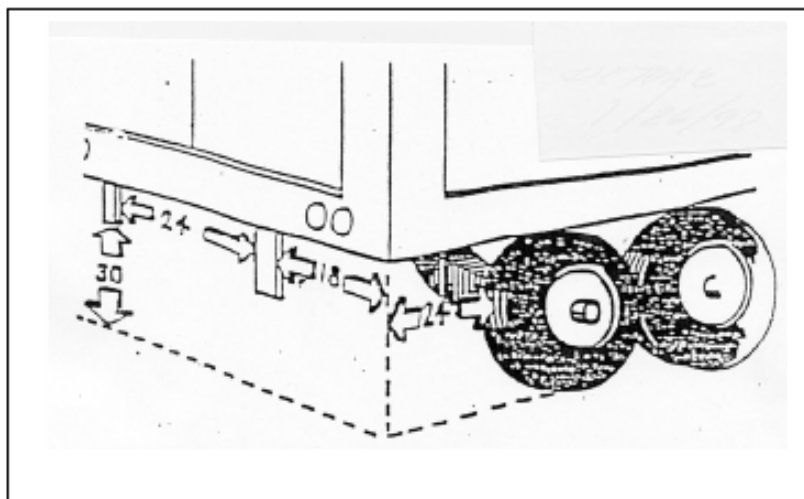

- Body/Chassis
 - More than 30" above ground
 - Empty
- Bumpers or Similar Device
 - Not exceed 30" from ground
 - Not exceed 24" between
 - Not exceed 18" from side
 - Not exceed 24" from rear
- Substantially Constructed
- Firmly Attached

REFLECTIVE TAPE FOR TRAILERS

On March 31, 1999, the Federal DOT issued a rule which requires trailers over 10,000 lbs. and 80 inches wide or more to be retrofitted with reflective tape (Ref. 393.13).

Trailers built on or after December 1, 1993, must already have reflective tape when built; that tape must be maintained in the same manner as when the trailer was new.

Trailers built before December 1, 1993, must be retrofitted with tape meeting the same color and reflection requirements.

White 12" inverted "L" along the top rear (with modifications for flat-beds and tankers).

Alternating red and white on lower rear and along the sides evenly spaced and covering at least half the length of the trailer:

- 14 feet on a 28-foot trailer
- 20 feet on a 40-foot trailer
- 24 feet on a 48-foot trailer
- 26½ feet on a 53-foot trailer

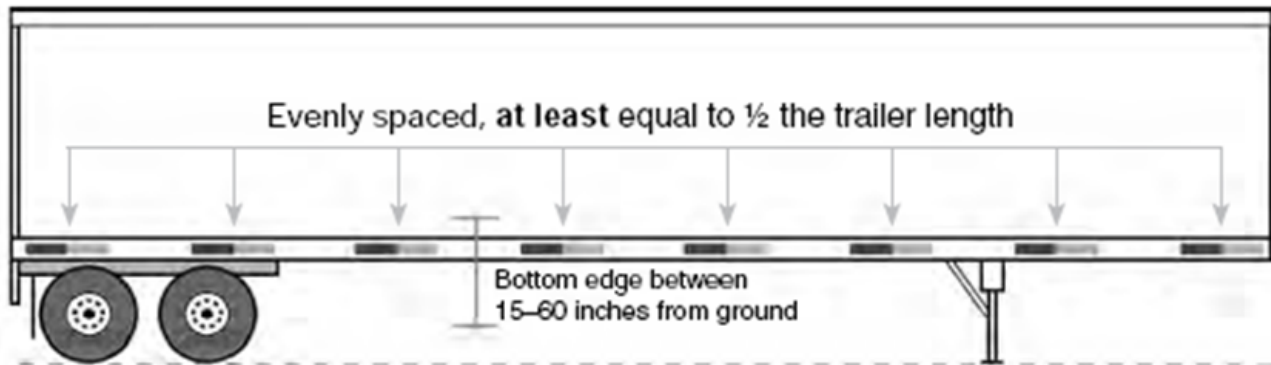

For box trailers, the rear reflective tape must be as shown:

- Full-width across the rear-end protection ("ICC bumper")
- Full-width across the lower rear cargo area
- Two 12" inverted "L" near the top rear corners

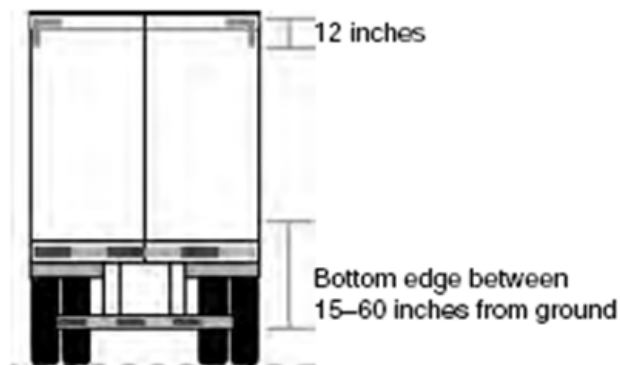

For flat-bed trailers, the rear tape must be has shown:

- Full-width across the rear-end protection (“ICC bumper”)
- Full-width across the lower rear cargo area
- Two 12" inverted “L” near the top rear header board

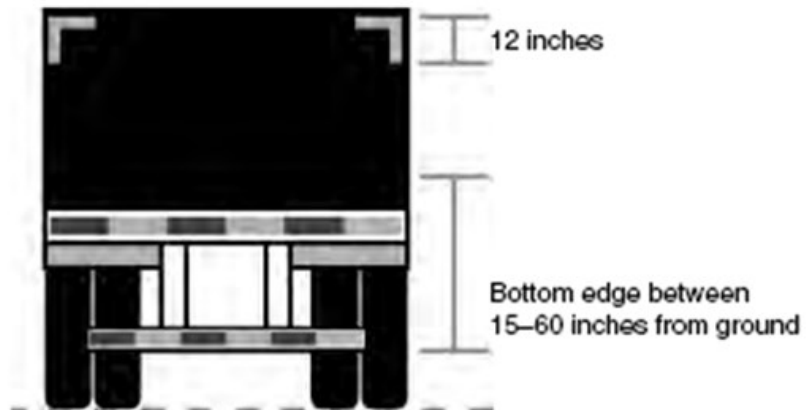

For tanker trailers, the rear tape must be has shown:

- Full-width across the rear-end protection
- Four 12" white strips near the top rear

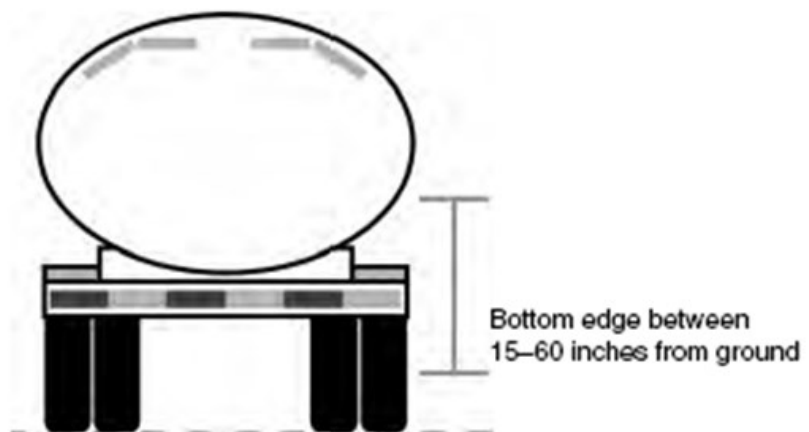

Trailers must be in compliance by June 1, 2001.
Trailers with tape colors other than red and white must be retrofitted by June 1, 2009.

Section 7

Accidents

The Code of Federal Regulations (CFR), Part 390.5 defines accident as an occurrence involving a commercial motor vehicle operating on a public road in interstate or intrastate commerce which results in:

- A fatality;
- Bodily injury to a person, who as a result of the injury, immediately receives medical treatment away from the scene of the accident; or
- Disabling damage to one or more motor vehicles requiring the motor vehicle to be transported away from the scene by a tow truck or other motor vehicle.

The term accident *does not* include:

- An occurrence involving only boarding and alighting from a stationary motor vehicle; or
- An occurrence involving only the loading of unloading or cargo; or
- An occurrence in the course of the operation of a passenger car or a multipurpose passenger vehicle by a motor carrier and is not transporting passengers for hire or hazardous materials of a type and quantity that require the motor vehicle to be marked or placarded in accordance with 49 CFR, Part 177.823.

Accident register required (see sample accident register form at the end of this section). 49 CFR, Part 390.15 requires that motor carriers maintain for a period of three years after an accident occurs, an accident register containing at least the following information:

- › Time and place of accident
- › Driver's name
- › Number of injuries and fatalities
- › Hazardous materials (other than fuel) released (if any)

The carrier must also maintain copies of all accident reports required by State or other governmental entities or insurers.

A Guide to Determining Preventability of Accidents

Description: A preventable accident is one that occurs because the driver fails to act in a reasonably expected manner to prevent it. In judging whether the driver's actions were reasonable, one seeks to determine whether the driver drove defensively and demonstrated an acceptable level of skill and knowledge. The judgment of what is reasonable can be based on a company-adopted definition, thus establishing a goal for its safety management programs.

Note that the above definition of a preventable accident is focused on the actions of the driver. It is the commonly used definition in evaluating driver performance. A broader definition, which can be used to evaluate the driver's and the motor carrier's actions, is given by the FMCSR as follows: Preventable accident on the part of the motor carrier means an accident that (1) involved a commercial motor vehicle, and (2) could have been averted but for an act, or failure to act, by the motor carrier, or the driver.

The heart of accident analysis is the determination of preventability, based on the facts furnished in the motor carrier's recordable accident register, and from various other sources. Each accident must be judged individually. Certain types will generally fall in the non-preventable category, and certain others, in the absence of extenuating circumstances and conditions, fall in the preventable category. The types of accidents shown below do not cover every accident that may occur, but they are intended to provide general guidance in determining preventability.

Non-preventable Accidents

Struck in rear by other vehicle Non-preventable if

- Driver's vehicle was legally and properly parked.
- Driver was proceeding in his/her own lane of traffic at a safe and lawful speed.
- Driver was stopped in traffic due to existing conditions or was stopped in compliance with traffic sign or signal or the directions of a police officer or other person legitimately controlling traffic.
- Driver was in proper lane waiting to make turn.

Struck while parked Non-preventable if

- Driver was properly parked in a location where parking was permitted.
- Vehicle was stopped, parked, or left standing in accordance with Section 392.21 and 392.22 of the Federal Motor Carrier Safety Regulations.
- Body/Chassis
 - › More than 30" above ground
 - › Empty
- Bumpers or Similar Device
 - › Not exceed 30" from ground
 - › Not exceed 24" between
 - › Not exceed 18" from side
 - › Not exceed 24" from rear
- Substantially Constructed
- Firmly Attached

Preventable Accidents

Accidents at intersections

Preventable if

- Driver failed to control speed so that he/she could stop within available sight distance.
- Driver failed to check cross-traffic and wait for it to clear before entering intersection.
- Driver pulled out from side street in the face of oncoming traffic.
- Driver collided with person, vehicle, or object while making right or left turn.
- Driver collided with vehicle making turn in front of him/her.

Striking other vehicle in rear

Preventable if

- Driver failed to maintain safe following distance and have his/her vehicle under control.
- Driver failed to keep track of traffic conditions and did not slow down.
- Driver failed to ascertain whether vehicle ahead was moving slowly, stopped, or slowing down for any reason.
- Driver misjudged rate of overtaking.
- Driver came too close before pulling out to pass.
- Driver failed to wait for vehicle ahead to move into the clear before starting up.
- Driver failed to leave sufficient room for passing vehicle to get safely back in line.

Sideswipe and head-on collisions

Preventable if

- Driver was not entirely in his/her proper lane of travel.
- Driver did not pull to right and slow down or stop for a vehicle encroaching on his/her lane of travel when such action could have been taken without additional danger.

Struck in rear by other vehicle

Preventable if

- Driver was passing slower traffic near an intersection and had to make sudden stop.
- Driver made sudden stop to park, load, or unload.
- Vehicle was improperly parked.
- Driver rolled back into vehicle behind them while starting on grade.

Squeeze plays and shutouts

Preventable if

- Driver failed to yield right-of-way when necessary to avoid accident.

Backing accidents

Preventable if

- Driver backed up when backing could have been avoided by better planning of his/her route.
- Driver backed into traffic stream when such backing could have been avoided.
- Driver failed to get out of cab and check proposed path of backward travel.
- Driver depended solely on mirrors when it was practicable to look back.
- Driver failed to get out of cab periodically and recheck conditions when backing a long distance.
- Driver failed to check behind vehicle parked at curb before attempting to leave parking space.
- Driver relied solely on a guide to help him/her back.
- Driver backed from blind side when he/she could have made a sight-side approach.

Accident involving rail-operated vehicles

Preventable if

- Driver attempted to cross tracks directly ahead of train or streetcar.
- Driver ran into side of train or streetcar.
- Driver stopped or parked on, or too close to, tracks.

Accidents while passing

Preventable if

- Driver passed where view of road ahead was obstructed by hill, curve, vegetation, traffic, adverse weather conditions, etc.
- Driver attempted to pass in the face of closely approaching traffic.
- Driver failed to warn driver of vehicle being passed.
- Driver failed to signal change of lanes.
- Driver pulled out in front of other traffic overtaking from rear.
- Driver cut in too short while returning to right lane.

Accidents while being passed

Preventable if

- Driver failed to stay in his/her own lane and hold speed, or reduce it, to permit safe passing.

Accidents while entering traffic stream

Preventable if

- Driver failed to signal when pulling out from curb.
- Driver failed to check traffic before pulling out from curb.
- Driver failed to look back to check traffic if he/she was in position where mirrors did not show traffic conditions.
- Driver attempted to pull out in a manner that forced other vehicles to change speed or direction.
- Driver failed to make full stop before entering from side street, alley, or driveway.
- Driver failed to yield right-of-way to approaching traffic.

Pedestrian accidents

Preventable if

- Driver did not reduce speed in area of heavy pedestrian traffic.
- Driver was not prepared to stop.
- Driver failed to yield right-of-way to pedestrian.

Mechanical defects accidents

Preventable if

- Defect was of a type that driver should have detected in making pre-trip or en-route inspection of vehicle.
- Defect was of a type that driver should have detected during the normal operation of the vehicle.
- Defect was caused by driver's abusive handling of the vehicle.
- Defect was known to the driver, but ignored.
- Driver was instructed to operate with known defect.

All types of accidents

Preventable if

- Driver was not operating at a speed suitable for the existing conditions of road, weather, and traffic.
- Driver failed to control speed so that he/she could stop within assured clear distance
- Driver misjudged available clearance.
- Driver failed to yield right-of-way to avoid accident.
- Driver failed to accurately observe existing conditions.
- Driver was in violation of company operating rules or special instructions, the regulations of an Federal or State regulatory agency, or any applicable traffic laws or ordinances.

REVENUE NECESSARY TO PAY FOR ACCIDENT LOSSES

This table shows the dollars of revenue required to pay for different amounts of costs for accidents.

Generally, it is necessary for a motor carrier to generate an additional \$1,250,000 of revenue to pay the cost of a \$25,000 accident, assuming an average profit of 2%. The amount of revenue required to pay for losses will vary with the profit margin (as shown in the chart below).

REVENUE REQUIRED TO COVER LOSSES

YEARLY ACCIDENT COSTS	VS. PROFIT MARGIN				
	1%	2%	3%	4%	5%
\$1,000	\$100,000	\$50,000	\$33,000	\$25,000	\$20,000
5,000	500,000	250,000	167,000	125,000	100,000
10,000	1,000,000	500,000	333,000	250,000	200,000
25,000	2,500,000	1,250,000	833,000	625,000	500,000
50,000	5,000,000	2,500,000	1,667,000	1,250,000	1,000,000
100,000	10,000,000	5,000,000	3,333,000	2,500,000	2,000,000
150,000	15,000,000	7,500,000	5,000,000	3,750,000	3,000,000
200,000	20,000,000	10,000,000	6,666,000	5,000,000	4,000,000

Accident costs consist of any/or all of the following:

- Vehicle damage
- Loss of revenue
- Administrative costs
- Police reports
- Cargo damage
- Possible effects on cost of insurance
- Possible effect on cost of Workmen's Compensation insurance
- Towing
- Storage of damaged vehicle
- Damage to customer relationships
- Legal fees
- Customer's loss of revenue directly attributable to accident

Section 8

Driver's Hours Of Service

(49 CFR, Part 395)

GENERAL RULES:

Recaps: It is recommended that carriers and drivers keep a summary (recap) of drivers' hours worked and hours available. This will help prevent hours of service violations.

Records of Duty Status required: Every carrier must require every driver to make a record of duty status for each 24-hour period, **unless** operating under the short-haul provisions described below.

Electronic Logging Device (ELD) required: Most motor carriers who are required to prepare hours-of-service records of duty status, are required to have an ELD. A motor carrier required to use an ELD must use only an ELD that is listed on the Federal Motor Carrier Safety Administration's registered ELDs list.

Exemptions to ELD requirements:

- Drivers who operate under the short-haul exceptions may continue using timecards; they are not required to keep RODS and will not be required to use ELDs.
- Drivers who use paper RODS for not more than 8 days out of every 30-day period.
- Drivers who conduct drive-away/tow-away operations, in which the vehicle being driven is the commodity being delivered.
- Drivers of vehicles manufactured before 2000.
- For more information see: <https://eld.fmcsa.dot.gov/FAQ/>

Forwarding to carrier: The driver must give or send by mail the original of the driver's records of duty status (log) to his/her employing carrier within 13 days after completing the record. When a motor carrier uses a driver initially or intermittently, that carrier must obtain from him/her a signed statement giving the total time on duty during the immediately preceding 7 days and the time at which he/she was last relieved of duty. (Sample form for recording this information is attached on following pages.)

The carrier must then keep the record of duty status (log) for 6 months at the carrier's principal place of business.

On duty time: All time from the time a driver begins to work or is required to be in readiness to work until the time the driver is relieved from work and all responsibility for performing work. As of February 27, 2012, on duty time does not include any time resting in a parked vehicle (property and passenger carriers) or up to two hours riding in the passenger seat of a moving property carrier vehicle immediately before or after a period of at least 8 consecutive hours in the sleeper berth.

Hours of Service Rules for Property-Carrying Operations:

Drivers of property carrying vehicles must comply with the following:

- May drive a maximum of 11 hours after 10 consecutive hours off duty.
- May not drive beyond the 14th consecutive hour after coming on duty, following 10 consecutive hours off duty.
- May not drive after 60/70 hours on duty in 7/8 consecutive days.
- CMV drivers using the sleeper berth provision must take at least 8 consecutive hours in the sleeper berth, plus 2 consecutive hours either in the sleeper berth, off duty, or any combination of the two.
- Motor Carrier must retain all supporting documents.

Short – Haul Provision

150 air-mile exemption: (For Property-carrying operations only) A driver does not have to create a record of duty status (log) if all of the following apply:

- The driver operates within a 150 air-mile radius of the normal work reporting location;
- The driver returns to the work reporting location and is released from work within 14 hours of initial reporting on-duty;
- At least 10 consecutive hours off-duty separate each 14 consecutive hours on duty;
- The motor carrier maintains and retains for 6 months accurate and true time records showing the following:
 - › The time the driver reports for duty each day;
 - › The total number of hours the driver is on-duty each day;
 - › The time the driver is released from duty each day; and
 - › The total time for the previous 7 days for drivers that are used for the first time or intermittently.
- Motor Carriers must retain each supporting document generated or received in the normal course of business including: bills of lading, itinerary, schedule, dispatch records, trip record, expense receipt, payroll records, electronic mobile communication record from fleet management systems, etc.

Note: Drivers utilizing the short-haul provision must adhere to the maximum driving time requirements in 49 CFR § 395.3.

16-Hour Short-Haul Exception

A non-CDL property-carrying driver may drive beyond the 14th consecutive hour after coming on-duty if all of the following apply:

- The driver operates within a 150 air-mile radius of the location where the driver reports to and is released from work;
- The driver returns to the normal work reporting location at the end of each duty tour;
- The driver does not drive after the 14th hour after coming on duty on 5 days of any period of 7 consecutive days; and
- The driver does not drive after the 16th hour after coming on duty on 2 days of any period of 7 consecutive days;
- The motor carrier maintains and retains for 6 months accurate and true time records showing the following:
 - › The time the driver reports for duty each day;
 - › The total number of hours the driver is on duty each day;
 - › The time the driver is released from duty each day; and
 - › The total time for the previous 7 days for drivers that are used for the first time or intermittently.

Short-haul drivers who normally use the 150-air-mile exemption and do not complete a standard grid log or electronic logging device will have to complete a log on days when they use this exception, because they are working beyond the 14-hour limit.

Note: There is no definition of “short haul” or “normal work reporting location.” These terms are generally understood to refer to drivers who start from and return to the same location on a daily basis.

Rest Breaks Required

Property Carrier drivers must not drive if more than 8 hours have passed since the driver last started driving without resting for a period of at least 30 minutes. Drivers may use on-duty not driving, sleeper berth or off-duty status as the 30 minute rest break. This rule does not apply to drivers operating under a short-haul provision.

34 Hour Restart

Property carrier drivers may end any period of 7/8 consecutive days with the beginning of an off-duty period of 34 or more consecutive hours.

Hours of Service Rules for Passenger-Carrying Operations:

Drivers of passenger carrying vehicles must comply with the following:

- May drive a maximum of 10 hours after 8 consecutive hours off duty.
- May not drive after having been on duty 15 hours following 8 consecutive hours off duty.
- May not drive after 60/70 hours on duty in 7/8 consecutive days
- CMV drivers using the sleeper berth provision must take at least 8 consecutive hours in the sleeper berth. This may be split into 2 periods, each at least 2 hours long.
- Motor Carrier must retain each supporting document generated or received in the normal course of business including: bills of lading, itinerary, schedule, dispatch records, trip record, expense receipt, payroll records, electronic mobile communication record from fleet management systems, etc.

Short – Haul Provision

150 air-mile exemption: (For Passenger-carrying operations only) A driver does not have to make a record of duty status (log) if all of the following apply:

- The driver operates within a 150 air-mile radius of the normal work reporting location.
- The driver returns to the work reporting location and is released from work within 14 consecutive hours.
- At least 8 consecutive hours off duty separate each 14 consecutive hours on duty.
- The driver does not exceed 10 hours maximum driving time following 8 consecutive hours off duty.
- The motor carrier maintains and retains for 6 months accurate and true time records showing the following:
 - › The time the driver reports for duty each day.
 - › The total number of hours the driver is on duty each day.
 - › The time the driver is released from duty each day.
- Motor Carrier must retain each supporting document generated or received in the normal course of business including: bills of lading, itinerary, schedule, dispatch records, trip record, expense receipt, payroll records, electronic mobile communication record from fleet management systems, etc.

Logbook Sample

DRIVER'S DAILY LOG
(ONE CALENDAR DAY - 24 HOURS)

ORIGINAL - Submit to carrier within 13 days
DUPLICATE - Driver retains possession for eight

Vehicle identification

VEHICLE NUMBERS - (SHOW EACH UNIT)

Drivers signature

DEPARTMENT OF TRANSPORTATION

Enter month, day, and year

(MONTH) (DAY) (YEAR)

Total miles driven today

(TOTAL MILES DRIVING TODAY)

Name of carrier

(NAME OF CARRIER OR CARRIERS)

Main office address

(MAIN OFFICE ADDRESS)

Name of co-driver or N/A

(NAME OF CO-DRIVER)

I certify these entries are true and correct:

(DRIVER'S SIGNATURE IN FULL)

MID-NIGHT	1	2	3	4	5	6	7	8	9	10	11	TOTAL HOURS
1: OFF DUTY	[Bar chart showing 11 hours of off-duty time]											11
2: SLEEPER BERTH	[Bar chart showing 0 hours of sleeper berth time]											0
3: DRIVING	[Bar chart showing 8.5 hours of driving time]											8.5
4: ON DUTY (NOT DRIVING)	[Bar chart showing 4.5 hours of on-duty non-driving time]											4.5
REMARKS												24

Shipping document number(s) or Name of shipper and commodity

Pro or Shipping No. _____

Change of duty status location with city and state. If staying in same city, use intersections.

Lacey, WA

Seattle, WA

Lacey, WA

U.S. DEPARTMENT OF TRANSPORTATION

DRIVER'S DAILY LOG
(ONE CALENDAR DAY - 24 HOURS)

ORIGINAL - Submit to carrier within 13 days
DUPLICATE - Driver retains possession for eight days

(MONTH) (DAY) (YEAR)

(TOTAL MILES DRIVING TODAY)

VEHICLE NUMBERS - (SHOW EACH UNIT)

I certify these entries are true and correct:

(NAME OF CARRIER OR CARRIERS)

(DRIVER'S SIGNATURE IN FULL)

(MAIN OFFICE ADDRESS)

(NAME OF CO-DRIVER)

	MID-NIGHT	1	2	3	4	5	6	7	8	9	10	11	NOON	1	2	3	4	5	6	7	8	9	10	11	TOTAL HOURS
1: OFF DUTY																									
2: SLEEPER BERTH																									
3: DRIVING																									
4: ON DUTY (NOT DRIVING)																									
REMARKS																									

Pro or Shipping No. _____

Employee Signature _____ Employee Number _____

SUNDAY		MONDAY		TUESDAY		WEDNESDAY		THURSDAY		FRIDAY		SATURDAY	
Date:		Date:		Date:		Date:		Date:		Date:		Date:	
TIME	ON DUTY HRS.	TIME	ON DUTY HRS.	TIME	ON DUTY HRS.	TIME	ON DUTY HRS.	TIME	ON DUTY HRS.	TIME	ON DUTY HRS.	TIME	ON DUTY HRS.
O	N	O	N	O	N	O	N	O	N	O	N	O	N
O		O		O		O		O		O		O	
F		F		F		F		F		F		F	
F		F		F		F		F		F		F	
O		O		O		O		O		O		O	
N		N		N		N		N		N		N	
O		O		O		O		O		O		O	
F		F		F		F		F		F		F	
F		F		F		F		F		F		F	
O		O		O		O		O		O		O	
N		N		N		N		N		N		N	
O		O		O		O		O		O		O	
F		F		F		F		F		F		F	
F		F		F		F		F		F		F	
O		O		O		O		O		O		O	
N		N		N		N		N		N		N	
O		O		O		O		O		O		O	
F		F		F		F		F		F		F	
F		F		F		F		F		F		F	
Total On-Duty Hours		Total On-Duty Hours		Total On-Duty Hours		Total On-Duty Hours		Total On-Duty Hours		Total On-Duty Hours		Total On-Duty Hours	
Total On-duty Hours Last 7 days		Total On-duty Hours Last 7 days		Total On-duty Hours Last 7 days		Total On-duty Hours Last 7 days		Total On-duty Hours Last 7 days		Total On-duty Hours Last 7 days		Total On-duty Hours Last 7 days	

DRIVER'S TIME RECORD

Driver's Name (print) _____ Employee No. _____ Month _____ Year _____

DRIVERS MAY PREPARE THIS REPORT INSTEAD OF "DRIVERS DAILY LOG" IF THE FOLLOWING APPLIES:

- * Operates within 150 mile radius.
- * Returns to headquarters and is released from work within 14 consecutive hours.
- * At least 10 consecutive hours off duty separate each 14 hours of duty (property).
- * At least 8 consecutive hours off duty separate each 14 hours of duty (passenger).

INTERMITTENT DRIVERS
 Shall complete this form for 7 days preceding any day driving is performed.
 This includes the preceding month.

Date	Start Time "All Duty"	End Time "All Duty"	Total Hours	Driving Hours	Truck Number	Headquarters
1						
2						
3						
4						
5						
6						
7						
8						
9						
10						
11						
12						
13						
14						
15						
16						
17						
18						
19						
20						
21						
22						
23						
24						
25						
26						
27						
28						
29						
30						
31						

To be prepared monthly by each DOT certified driver unless time record is exclusively kept on Driver's Daily Log. Indicate "days off". Check box if no driving is performed during this month and the first 7 days of the following month. Mail this report to your Division Manager of Administration.

Hours-Of-Service Record for First Time or Intermittent Drivers

Instructions: When using a driver for the first time or intermittently, a signed statement must be obtained, giving the total time on duty (driving and on-duty) during the immediately preceding seven days and the time at which the driver was last relieved from duty prior to beginning work.

Name (Printed) _____	
<u>Day</u>	<u>Total time on duty</u>
1	_____
2	_____
3	_____
4	_____
5	_____
6	_____
7	_____
	Total _____
I hereby certify that the information contained hereon is true to the best of my knowledge and belief, and that my last period of release from duty was from	
_____	to _____
(Hour/date)	(Hour/date)
Driver's Signature _____	Date _____

Section 9

Inspection, Repair, And Maintenance

(49 CFR, Part 396)

Each carrier must inspect, repair, and maintain all motor vehicles under its control.

Required records:

- Identification of the vehicle including company number (if so marked), make, serial number, year, and tire size. Also, if the carrier does not own the vehicle, the records must show the name of the person providing the vehicle.
- A preventative maintenance schedule.
- Record of inspection, repairs, and maintenance conducted on all vehicles.
- A record of tests conducted on push-out windows, emergency doors, and emergency door marking lights on buses. These tests must be conducted at least once every 90 days

Record Retention: Maintenance records must be kept for a period of one year where the vehicle is housed or maintained.

They must be kept for a period of at least 6 months after the vehicle leaves the carrier's control.

Roadside inspection reports: Any driver who receives a roadside inspection report must deliver it to his/her employing motor carrier. An official of the motor carrier must examine the roadside inspection report and ensure that any violations or defects noted on the report are corrected. The motor carrier must sign the report and maintain a copy for 12 months from the date of the inspection.

Pre-trip Inspection: Before starting out, the driver must be satisfied that the motor vehicle is in safe operating condition. If the last driver vehicle inspection report (DVIR) notes any defects, the driver must review and sign to acknowledge that necessary repairs have been completed.

Driver Vehicle Inspection Report (DVIR): Every carrier must require its drivers to complete a DVIR at the end of each day if defects are found.. The report must identify the commercial motor vehicle and list any defects that could affect its safe operation. Every driver is responsible for preparing such a report for each commercial motor vehicle driven.

NOTE: This publication not intended for sale.

The DVIR report must cover at least the following parts and accessories:

<ul style="list-style-type: none"> • Service brakes (including trailer brake connections). • Parking (hand) brakes. • Steering mechanism. • Lighting devices and reflectors. • Tires. 	<ul style="list-style-type: none"> • Horn. • Windshield wipers. • Coupling devices. • Wheels and rims. • Emergency equipment. • Rear Vision Mirrors.
--	--

Every carrier must keep the original DVIR, the certification or repairs, and the certification of the driver’s review for at least three months. The report must contain all required signatures. All defects that affect the safe operation of the vehicle(s) must be corrected prior to dispatching the vehicle.

Periodic Inspection:

- Conducted on all motor vehicles under the carrier’s control.
- At least once a year.
- Inspect all Appendix G components (refer to example).
- Retain a copy of the periodic inspection where the vehicle is housed or maintained.
- Retain proof of the periodic inspection on the vehicle.

Periodic Inspector’s Qualifications:

Motor carriers must ensure that persons performing periodic inspections are qualified. Inspectors must:

- Understand the inspection standards of Part 393 and Appendix G.
- Be able to identify defective components.
- Have knowledge and proficiency in methods, procedures, and tools.

Inspectors may have gained experience or training by:

- Completing a State or Federal training program, or earning a State or Canadian Province qualifying certificate in commercial motor vehicle safety inspections.
- A combination of other training or experience totaling at least one year.

Motor carriers must retain evidence of an inspector’s qualifications until one year after the inspector ceases to perform inspections for the carrier.

Brake inspector qualification:

The motor carrier is responsible for ensuring that all inspections, maintenance, repairs, and service to brakes of commercial motor vehicles comply with these regulations. The carrier must ensure that the employees responsible for brake inspection, maintenance, service, or repairs meet minimum brake inspector qualifications.

The brake inspector must:

- Understand and be able to perform the brake service and inspection.
- Know the methods, procedures, tools and equipment needed.
- Be qualified to perform brake service or inspection by training and/or experience.

Qualifying brake training or experience includes successful completion of:

- A State, Canadian Province, Federal agency, or union training program.
- A State-approved training program.
- Training that led to attainment of a State or Canadian Province qualifying certificate to perform assigned brake service or inspection tasks, including passage of CDL air brake test in the case of a brake inspection.

OR

- One year of brake-related training, experience, or a combination of both.

Motor carriers must maintain evidence of inspector qualifications at the principal place of business or the location where the inspector works. Evidence must be retained for the period during which the brake inspector is employed in that capacity, and for one year thereafter.

Sample maintenance forms/records and pre-trip and post trip inspection diagrams are contained at the end of this section.

DRIVER'S WALK-AROUND SAFETY INSPECTION

Based on the North American Standard Inspection Procedures

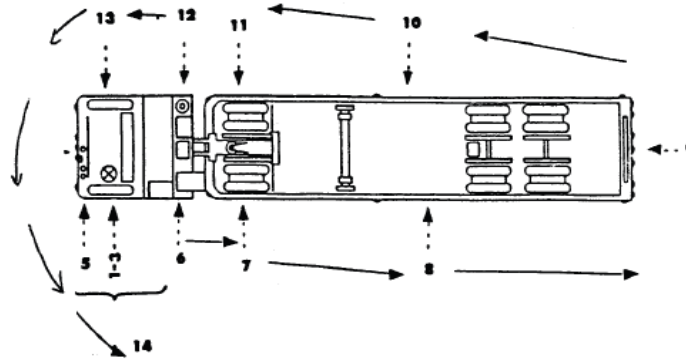

THE PRE-TRIP:

1. PREPARING THE VEHICLE

- Note general condition. If unit is leaning it may indicate broken spring, poor load distribution or flat tire. Look for signs of fuel, oil or water leaks. Ensure parking brake is applied.
- Review last vehicle inspection report. Note any defects reported by previous driver. Confirm necessary repairs were made.

2. ENGINE COMPARTMENT

- Check all hoses for signs of leakage or seeping.
- Wiring—Check for cracked or worn insulation.

3. INSIDE CAB

- Start engine—Listen for any unusual noise.
- Check gauges—Including oil pressure, ammeter and/or voltmeter, coolant temperature, engine oil temperature and warning devices.
- Condition of controls—Check for looseness, sticking, damage or improper setting of steering wheel, clutch, accelerator, foot brake, trailer brake, parking brake, retarder controls, transmission controls, interaxle differential lock, horn(s), wiper/washer, headlights, dimmer switch, turn signals, 4-way flashers and clearance marker lights.
- Seats, seat belts.
- Windshield, and mirrors—Check for cracks, dirt, and illegal stickers.
- Wipers—Check for operation.
- Emergency equipment—Spare fuses (if applicable), three reflective triangles, properly charged and rated fire extinguisher within arm's reach of driver's seat. Flares, lanterns and flags are optional.
- Check for excessive play in steering wheel. (Manual steering play should not exceed power steering should be less than 45 degrees.)

4. FRONT OF CAB

- Steering system—Look for loose, worn, bent, damaged or missing parts.
- Headlamps, turn signals, and emergency flashers—Check for proper color and operation.

- Suspension (both sides)—Check leaf springs for broken or missing parts, leaves out of alignment, or contact with the vehicle body. Check U-bolts for loose, cracked or missing parts. Check mounting hardware for cracks, missing bolts, or pins.
- Front Brakes (both sides)—Assure all components are attached and operational. Check brake lines for leaks or damage and chambers (if visible) for cracks or insecure mounting. Check brake linings. They should be free of large cracks or missing pieces. No grease or oil should be on the linings or drums. Make certain the pushrod and slack adjuster are mechanically operational. Check for audible air leaks. (If possible, ask a helper to apply the brakes, hold them, then release them when you signal. Check for excessive slack adjuster travel. If visible, check brake drums for external cracks that open upon application.)

5. LEFT SIDE OF CAB

- Left front wheel—Check for defective welds, cracks or breaks, especially between hand holds or stud holes; unseated locking rings; broken, missing or loose lugs, studs or clamps; bent or cracked rims. Check for "bleeding" rust stains, defective nuts or elongated stud holes. Spoke wheels should be checked for cracks across spokes. Scrubbed or polished areas on either side of the lug indicate a slipped rim. Rims should also be checked for cracks or bends. Valve stem should be straight and equidistant from wheel spokes.
- Left front tire —Check for bulges, leaks, sidewall separations, cuts, exposed fabric, worn spots. Check for proper inflation. Measure the tread depth (2/32" minimum). Check for tire contact with any part of the vehicle.
- Frame—Look for cracked, sagging rails. Check for broken or loose bolts or brackets.

(Form 27 – Rev. 10-2001)

6. LEFT FUEL TANK AREA

- Left fuel tank(s)—Check fuel level. Check for insecure mounting, leaks, or other damage. Check for unsecured cap(s) or loose connections. Verify that the fuel crossover line is secure.
- Air and electrical lines—Check the lines between the tractor and the trailer for tangles, crimps or chafing or dragging. Check connections. Listen for leaks.
- Hose couplers (glad hands)—Check mounting. Look for leaks or other damage.
- Frame—Look for cracked, sagging rails. Check for broken or loose bolts or brackets.

7. LEFT REAR TRACTOR AREA

- Wheels, rims and tires—Inspect as described in Item 5. Examine inside tire, making sure both tires are same height. Check between tires for debris or contact. Check for flat tires inside or outside.
- Suspension and brakes—Inspect as described in item 4.
- Fifth wheel—Check for cracks along the fifth wheel plate and mounting area.
- Ensure locking jaws are properly engaged. Check for loose or missing nuts and bolts. Operating handle should be closed and latched. (For sliding fifth wheels, make sure the slider is locked.)
- Lamps—Check tractor stop lamps and turn signals for color and operation.
- Frame—Look for cracked, sagging rails. Check for broken or loose bolts or brackets.

8. LEFT SIDE OF TRAILER

- Wheels, rims and tires—Inspect as described in Item 5.
- Visible suspension and brake components—Inspect as described in Item 4.
- Cargo securement—For flatbeds, check header board for proper type and mounting. Check blocking and bracing, chains, straps and side posts. Check for shifted cargo. Check tarps.
- Check for burned out or missing market lights, reflectors.

9. REAR OF TRAILER

- Stop lamps, tail lamps, turn signals, emergency flashers, reflectors, and clearance and marker lights—Check for proper operation, color, and cleanliness.
- Suspension—Check as described in Item 4.
- Brakes—Check as described in Item 4.
- Rear bumper—Check for damage, missing pieces.
- Tires, wheels—Check as described in Item 5.
- Cargo securement—Verify that doors are locked/latched. For flatbeds, inspect as described in Item 8.
- Markings—Check for proper placarding, license plate light operable.
- Frame—Look for cracked, sagging rails. Check for broken or loose bolts or brackets.

10. RIGHT SIDE OF TRAILER

- Check all items as on left side.
- Spare tire—check for secure mounting, proper inflation.
- Landing gear or dollies—Should be fully raised. Check for missing, bent or damaged parts, secured crank handle.

11. RIGHT REAR TRACTOR AREA

- Check all items as on left side (See Item 7.)

12. RIGHT FUEL TANK AREA

- Exhaust system—Check for secure mounting, leaks (under cab), exhaust contacted by fuel or air lines or electrical wires. Look for carbon deposits around seams and clamps indicating exhaust leaks.
- Check all items as on left side.

13. RIGHT SIDE OF CAB

- Check all items as on left side. (See Item 5.)

14. RETURN TO CAB

- Air pressure—Pump up air system, check gauge. Check low air pressure warning device by depleting air supply (pump the foot brake valve). Warning light/buzzer should activate at about 55 psi or above.
- Parking brakes—With seat belt fastened, release brakes. As vehicle begins to move, activate parking brakes to check operation.
- Service brakes—At about 5 mph, apply brakes. Note any unusual pulling, delay or play in the brake pedal.
- Paperwork—Update logbooks, sign off on Vehicle Inspection Report, check for proper bills of lading, licenses on both vehicles, placards, permits and inspection stickers and medical certificate and waiver if required.

THE POST TRIP:

Every motor carrier shall require its drivers to report, and every driver shall prepare a report, in writing at the completion of each day's work on each vehicle operated.

The inspection and report shall cover at least the following parts and accessories:

- Service brakes including trailer brake connections;
- Parking (hand) brake;
- Steering mechanism;
- Lighting devices and reflectors;
- Tires;
- Horn;
- Windshield wipers;
- Rear vision mirrors;
- Coupling devices;
- Wheels and rims; and
- Emergency equipment.

To complete this inspection, refer to the sections related to the above-listed items on the pre-trip inspection guide.

DRIVER/VEHICLE INSPECTION REPORT (49 CFR 396.11)

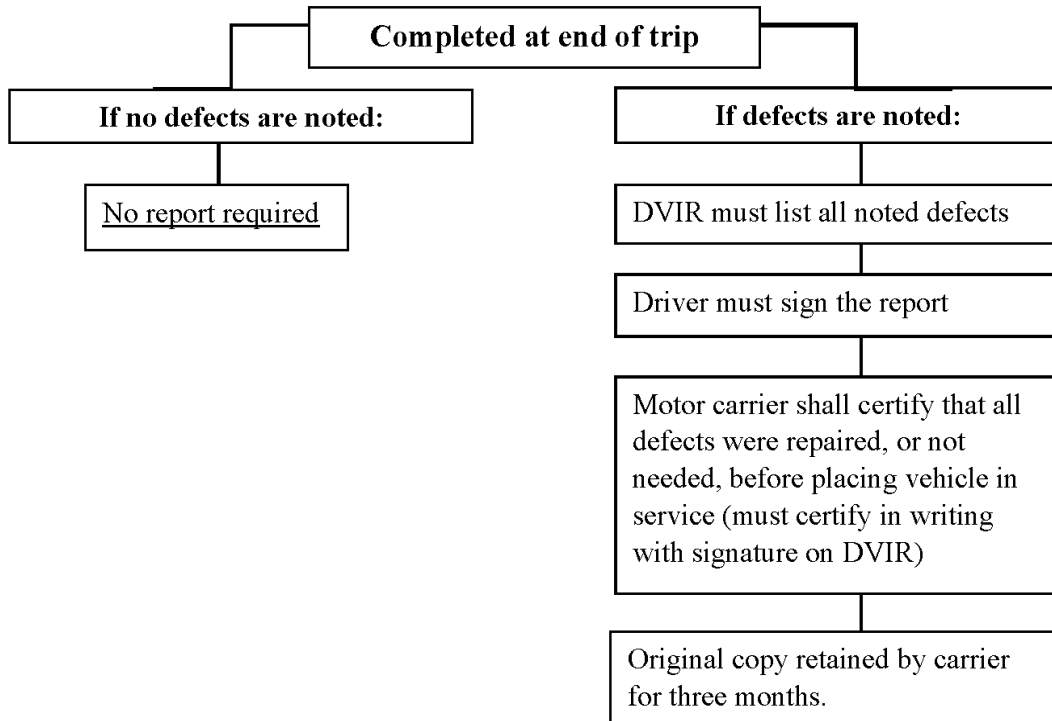

PRE-TRIP INSPECTION (49 CFR, PART 396.13)

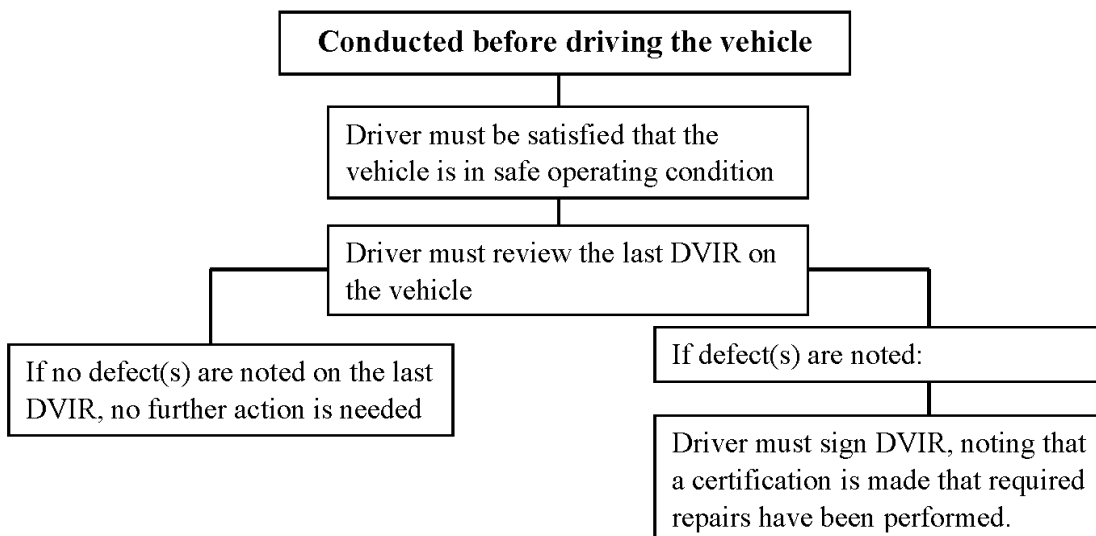

Driver Vehicle Inspection Report

Date: _____ Vehicle Number: _____

Driver instruction: Check any defective items that were observed by or reported to you. Give details under "Remarks".

____ Service Brakes, Parking Brakes

____ Windshield Wipers

____ Steering

____ Mirrors

____ Lights

____ Coupling Devices

____ Tires

____ Wheels and Rims

____ Horn

____ Emergency Equipment

Other: _____

Remarks: _____

____ Condition of the above vehicle is Satisfactory.

Driver's Signature: _____

____ Above defects corrected.

____ Above defects need not be corrected for safe vehicle operation.

Mechanic's or carrier official's signature certifying repairs:

_____ Date: _____

Next day driver's signature:

_____ Date: _____

This report to be maintained for 90 days from date prepared.

Driver's Vehicle Inspection Report

Check any defective Item and give details under "Remarks."

DATE: _____

TRUCK/TRACTOR NO. _____

- | | | |
|---|---|--|
| <input type="checkbox"/> Air Compressor
<input type="checkbox"/> Air Lines
<input type="checkbox"/> Battery
<input type="checkbox"/> Brake Accessories
<input type="checkbox"/> Brakes
<input type="checkbox"/> Carburetor
<input type="checkbox"/> Clutch
<input type="checkbox"/> Defroster
<input type="checkbox"/> Drive Line
<input type="checkbox"/> Engine
<input type="checkbox"/> Fifth Wheel
<input type="checkbox"/> Front Axle
<input type="checkbox"/> Fuel Tanks
<input type="checkbox"/> Heater | <input type="checkbox"/> Horn
<input type="checkbox"/> Lights
<input type="checkbox"/> Head - Stop
<input type="checkbox"/> Tail - Dash
<input type="checkbox"/> Turn Indicators
<input type="checkbox"/> Mirrors
<input type="checkbox"/> Muffler
<input type="checkbox"/> Oil Pressure
<input type="checkbox"/> On-Board Recorder
<input type="checkbox"/> Radiator
<input type="checkbox"/> Rear End
<input type="checkbox"/> Reflectors
<input type="checkbox"/> Safety Equipment
Fire Extinguisher
Flags-Flares-Fusees
Spare Bulbs & Fuses
Spare Seal Beam | <input type="checkbox"/> Springs
<input type="checkbox"/> Starter
<input type="checkbox"/> Steering
<input type="checkbox"/> Tachograph
<input type="checkbox"/> Tires
<input type="checkbox"/> Transmission
<input type="checkbox"/> Wheels
<input type="checkbox"/> Windows
<input type="checkbox"/> Windshield Wipers
<input type="checkbox"/> Other |
|---|---|--|

TRAILER(S) NO.(S) _____

<input type="checkbox"/> Brake Connections <input type="checkbox"/> Brakes <input type="checkbox"/> Coupling Chains <input type="checkbox"/> Coupling (King) Pin <input type="checkbox"/> Doors	<input type="checkbox"/> Hitch <input type="checkbox"/> Landing Gear <input type="checkbox"/> Lights - All <input type="checkbox"/> Roof <input type="checkbox"/> Springs	<input type="checkbox"/> Tarpaulin <input type="checkbox"/> Tires <input type="checkbox"/> Wheels <input type="checkbox"/> Other
---	---	---

Remarks: _____

CONDITION OF THE ABOVE VEHICLE IS SATISFACTORY

Driver's Signature _____

- ABOVE DEFECTS CORRECTED
 ABOVE DEFECTS NEED NOT BE CORRECTED FOR SAFE OPERATION OF VEHICLE

MECHANIC'S SIGNATURE _____ DATE: _____
 OWNING DRIVER'S SIGNATURE _____ DATE: _____

Annual Vehicle Inspection Report

Vehicle History Record	
Report Number	FLEET UNIT NUMBER
DATE	

MOTOR CARRIER OPERATOR	INSPECTOR'S NAME (PRINT OR TYPE)
ADDRESS	THIS INSPECTOR MEETS THE QUALIFICATION REQUIREMENTS IN SECTION 396.19. <input type="checkbox"/> YES
CITY, STATE, ZIP CODE	VEHICLE IDENTIFICATION (✓) AND COMPLETE <input type="checkbox"/> LIC. PLATE NO. <input type="checkbox"/> VIN <input type="checkbox"/> OTHER
VEHICLE TYPE <input type="checkbox"/> TRACTOR <input type="checkbox"/> TRAILER <input type="checkbox"/> TRUCK <input type="checkbox"/> (OTHER)	INSPECTION AGENCY/LOCATION (OPTIONAL)

VEHICLE COMPONENTS INSPECTED

ITEM	OK	NEEDS REPAIR	REPAIRED DATE	ITEM	OK	NEEDS REPAIR	REPAIRED DATE
1. BRAKE SYSTEM				7. STEERING MECHANISM			
a. Service Brakes				a. Steering Wheel Free Play			
b. Parking Brake System				b. Steering Column			
c. Brake Drums or Rotors				c. Front axle beam and ALL steering components other than steering column			
d. Brake Hose				d. Steering Gear Box			
e. Brake Tubing				e. Pitman Arm			
f. Low Pressure Warning Device				f. Power Steering			
g. Tractor Protection Valve				g. Ball and Socket Joints			
h. Air Compressor				h. Tie Rods and Drag Links			
i. Electric Brakes				i. Nuts			
j. Hydraulic Brakes				j. Steering System			
k. Vacuum Systems				8. SUSPENSION			
2. COUPLING DEVICES				a. Any U-bolt(s), spring hanger(s), or other axle positioning part(s) cracked, broken, loose or missing resulting in shifting of an axle from its normal position.			
a. Fifth Wheels				b. Spring Assembly			
b. Pintle Hooks				c. Torque, Radius, or Tracking Components			
c. Drawbar/Towbar Eye				9. FRAME			
d. Drawbar/Towbar Tongue				a. Frame Members			
e. Safety Devices				b. Tire and Wheel Clearance			
f. Saddle-Mounts				c. Adjustable Axle Assemblies (Sliding Subframes)			
3. EXHAUST SYSTEM				10. TIRES			
a. Any exhaust system determined to be leaking of a point forward of or directly below the driver/sleeper compartment.				a. Tires on any steering axle of a power unit.			
b. A bus exhaust system leaking or discharging to the atmosphere in violation of standards (1), (2), or (3).				b. All other tires.			
c. No part of the exhaust system of any motor vehicle shall be so located as would be likely to result in burning, charring, or damaging the electrical wiring, the fuel supply, or any combustible part of the motor vehicle.				11. WHEELS AND RIMS			
4. FUEL SYSTEM				a. Lock or Side Ring			
a. Visible leak				b. Wheels and Rims			
b. Fuel tank filler cap missing				c. Fasteners			
c. Fuel tank securely attached				d. Welds			
5. LIGHTING DEVICES				12. WINDSHIELD GLAZING			
All lighting devices and reflectors required by Section 393 shall be operable.				Requirements and exceptions as stated pertaining to any crack, discoloration or vision reducing matter (reference 393.60 for exceptions).			
6. SAFE LOADING				13. WINDSHIELD WIPERS			
a. Part(s) of vehicle or condition of loading such that the spare tire or any part of the load or dunnage can fall onto the roadway.				Any power unit that has an inoperative wiper, or missing or damaged parts that render it ineffective.			
b. Protection against shifting cargo				List any other condition which may prevent safe operation of this vehicle.			

Instructions: Mark column entries to verify inspection: X OK, X NEEDS REPAIR, NA IF ITEMS DO NOT APPLY, REPAIRED DATE.
 CERTIFICATION: THIS VEHICLE HAS PASSED ALL THE INSPECTION ITEMS FOR THE ANNUAL VEHICLE INSPECTION REPORT IN ACCORDANCE WITH 49 CFR 396.

INSPECTOR QUALIFICATIONS – Certification – 49 CFR – Part 396.19

Motor carriers are responsible for ensuring that individuals performing an annual inspection under 396.19 are qualified as follows:

- Understands the inspection criteria set forth in Part 393 and Appendix G, and can identify defective components.
- Is knowledgeable of and has mastered the methods, procedures, tools, and equipment used when performing an inspection.
- Is capable of performing an inspection by reason of experience, training, or both, and qualifies in one of the following categories (check all that apply):
1. Successfully completed a State or Federal training program, or has a certificate from a State or Canadian Province that qualifies the person to perform commercial vehicle safety inspection. Specify: _____

or
 2. Have a combination of training or experience totaling at least one year as follows (check all that apply):
 - A. Participation in a truck manufacturer-sponsored training program or similar commercial training program designed to train students in truck operation and maintenance. Where and date:

 - B. _____ years experience as a mechanic or inspection in a motor carrier maintenance program. Name and date:

 - C. _____ years experience as a mechanic or inspection in truck maintenance at a commercial garage, fleet leasing company, or similar facility. Name of facility and dates:

 - D. _____ years experience as a commercial vehicle inspector for a State, Provincial, or Federal Government. Where and dates:

I certify the above information is true and accurate to the best of my knowledge.

Signature of Mechanic/Inspector _____ Date _____

Signature of Motor Carrier/
Company Employer/Supervisor _____ Date _____

Evidence of Inspector qualification are on file at: _____

BRAKE INSPECTION QUALIFICATIONS

Certification – 49 CFR – Part 396.25

“Brake Inspector” means any employee of a motor carrier who is responsible for ensuring all brake inspections, maintenance, service, or repairs to any commercial motor vehicle, subject to the motor carrier’s control, meet the applicable Federal standards.

No motor carrier shall require or permit any employee who does not meet minimum brake inspector qualifications to be responsible for the inspection, maintenance, service, or repairs of any brakes on its commercial motor vehicles.

Minimum Qualifications

- Understands and can perform brake service and inspection.
- Is knowledgeable of and has mastered the methods, procedures, tools, and equipment necessary to perform brake service and inspection.
- Is capable of performing brake service or inspection by reason of experience, training, or both, and qualifies in one of the following categories (check all that apply):
1. Has successfully completed an apprenticeship program sponsored or approved by a State, Canadian Province, a Federal agency, or labor union, or has a certificate from a State or Canadian Province that qualifies the person to perform brake service or inspections. Specify:

or

 2. Has brake-related training or experience or both, totaling at least one year as follows):
 - A. Participation in a brake maintenance or inspection training program sponsored by a brake or vehicle manufacturer or similar commercial training program. Where and date:

 - B. _____ years experience performing brake maintenance or inspection in a motor carrier maintenance program. Name and date:

 - C. _____ years experience performing brake maintenance or inspection at a commercial garage, fleet leasing company, or similar facility. Name of facility and dates:

I certify the above information is true and accurate to the best of my knowledge.

Signature of Mechanic/Inspector _____ Date _____

Signature of Motor Carrier/
Company Employer/Supervisor _____ Date _____

Evidence of Inspector qualifications are on file at: _____

Section 10

Transportation Of Hazardous Material

(49 CFR, Part 397)

Hazardous materials are any substance defined by the Secretary of Transportation capable of posing an unreasonable risk to health and safety or to property. Hazardous materials fall into one of the following basic classes and divisions.

Explosives 1.1	Non-Flammable Gas, 2.2	Organic Peroxide, 5.2
Explosives 1.2	Poison Gas, 2.3	Poison Liquid or Solid, 6.1
Explosives 1.3	Flammable & Combustible	Infectious Substance, 6.2
Explosives 1.4	Liquids, 3	Radioactive, 7
Explosives 1.5	Flammable Solids, 4.1	Corrosive, 8
Explosives 1.6	Spontaneously Combustible, 4.2	Miscellaneous, 9
Flammable Gas, 2.1	Dangerous When Wet, 4.3	Consumer Commodities
	Oxidizer, 5.1	ORM-D

To determine if a material you are transporting is hazardous, contact the shipper that provided the material or see the definitions of these materials in the hazardous materials regulations.

A motor carrier that transports a hazardous material must comply with the Federal Hazardous Material Regulations, 49 CFR 100-180. These regulations include requirements for registration, training, shipping papers, labels, placards, and packages. In addition, there are additional requirements in the Federal Motor Carrier Safety Regulations, including insurance requirements, operational restrictions, Commercial Drivers’ License endorsements, routing, parking, attendance requirements for hazardous materials, and security plans.

To obtain additional information about hazardous material regulations, contact:

- FMCSA /WSP - (360) 753-9875, (360) 596-3800
- FMCSA - phmsa.dot.gov/hazmat
- FMCSA - www.fmcsa.dot.gov/regulations/hazardous-materials
- PHMSA - www.phmsa.dot.gov/hazmat 1-800-467-4922

NOTE: This publication not intended for sale.

Section 11

Commercial Vehicle Safety Alliance (CVSA)



CVSA members include the United States, Canada, Mexico, and associated industry members. The Washington Utilities and Transportation Commission and the Washington State Patrol are members of CVSA.

The goals of CVSA are:

- To bring about overall improvement in commercial vehicle and hazardous materials transportation safety.
- To avoid duplication of inspection efforts by the various jurisdictions.
- To minimize delays for the operating industry.
- To increase the number of on-highway inspections.
- To improve the safety of equipment and drivers operating on our highways.

CVSA Inspection Levels:

- Level 1 - North American Standard (NAS) Inspection*
- Level 2 - Walk-Around Driver/Vehicle Inspection
- Level 3 - Driver/Credential Inspection
- Level 4 - Special Inspections
- Level 5 - Vehicle-Only Inspection*
- Level 6 - Enhanced North American Standard (NAS) Inspection for Transuranic Waste and Highway Route Controlled Quantities (HRCQ) of Radioactive Material*
- Level 7 - Jurisdictional Mandated Commercial Vehicle Inspection

*Only vehicles passing Levels 1, 5, and 6 inspections receive CVSA decals.

- A vehicle that does not pass the CVSA inspection will not receive a CVSA decal and may be placed out of service, in accordance with the North American Standard Out-of-Service Criteria.
- Drivers may be placed out of service for various driver violations, such as logbook, licensing, etc.

Note: Copies of NAS out-of-service criteria used by all CVSA-affiliated states, provinces, and agencies are available to the public by contacting the address listed below.

Commercial Vehicle Safety Alliance

6303 Ivy Lane

Suite 310

Greenbelt, Maryland 20770-6319

Phone: (301) 830-6143

Fax: (301) 830-6144

cvсахq@cvsa.org

www.cvsa.org

DIFFERENCES IN THE LEVELS OF INSPECTION

Inspection Items	Level 1	Level 2*	Level 3	Level 4	Level 5**
1. Drivers license	✓	✓	✓		
2. Medical examiner's certificate and waiver (if applicable)	✓	✓	✓		
3. Alcohol and drugs	✓	✓	✓		
4. Drivers log (hours-of-service and duty status)	✓	✓	✓		
5. Seatbelt system	✓	✓	✓		✓
6. Periodic inspection documentation	✓	✓	✓		✓
7. Brake system	✓	✓			✓
8. Coupling devices	✓	✓			✓
9. Exhaust system	✓	✓			✓
10. Frame	✓	✓			✓
11. Fuel system	✓	✓			✓
12. Brake, head, tail lamps, turn signals, and lamps on projecting loads	✓	✓			✓
13. Safe loading of cargo	✓	✓			✓
14. Steering mechanism	✓	✓			✓
15. Suspension	✓	✓			✓
16. Tires	✓	✓			✓
17. Wheels, rims, and hubs	✓	✓			✓
18. Van and open-top trailer bodies	✓	✓			✓
19. Windshield wipers	✓	✓			✓
20. Emergency exits (for buses)	✓	✓			✓
21. Hazardous materials requirements (as applicable)	✓	✓	✓		✓
22. One time special inspection of a particular item				✓	
CVSA decal issued for "Pass" inspection (no violations/defects found in items 7-20)	✓				✓

Notes:

* Level 2 inspection only includes those items that can be inspected without physically getting under the vehicle

** Level 5 inspections are conducted without a driver present

Section 12

Safety Compliance Investigation

A terminal safety investigation is a comprehensive review of a motor carrier's compliance with all applicable federal and state safety regulations. This involves a review of the regulations with company management, review of documents relating to accidents, drivers and equipment, as well as inspection of equipment at the carrier's terminal.

Companies may receive a terminal safety review for one of the following reasons:

- To obtain a current safety rating
- Safety complaints
- Upon carrier request
- Routine Compliance Reviews
- High accident ratio
- High vehicle defect ratio
- Previous "Conditional" and/or "Unsatisfactory" safety rating

What can a carrier expect when contacted for a terminal safety investigation? An investigator will contact the carrier official and make an appointment to do the terminal audit. In addition, the investigator will provide the official with information regarding the types of records and vehicles that will be inspected during the course of this safety review.

The following parts and subparts contained in Title 49 CFR, will be inspected for compliance:

- **Part 40 – Procedure for Transportation Workplace Drug and Alcohol Testing Programs**
- **Part 380 – Special Training Requirements**
- **Part 382 – Controlled substance and alcohol use and testing.** (Applies to every person who operates a commercial motor vehicle in interstate or intrastate commerce and who is subject to commercial driver's license (CDL) requirements.)
- **Part 383 – Commercial Driver's License Standards**
- **Part 385 – Safety Fitness Procedure**
- **Part 387 – Minimum Levels of Financial Responsibility for Motor Carriers and/or Intrastate Insurance Requirements**
- **Part 390 – Accident Register**
- **Part 391 – Qualifications of Drivers**
- **Part 392 – Parts and Accessories Necessary for Safe Operations**
- **Part 395 – Hours of Service for Drivers** (Or Washington Administrative Codes for certain drivers hours of service regulations.)
- **Part 396 – Inspection, Repair and Maintenance**
- **Part 397 – Transportation of Hazardous Materials; Driving and Parking Rules**
- **Parts 100 through 177 -- Hazardous Materials Regulations**

NOTE: This publication not intended for sale.

Upon completion of a UTC safety compliance review, the carrier will receive an intrastate safety rating. This rating will consist of one of the following:

- **Satisfactory**
- **Conditional**
- **Unsatisfactory**

Carrier officials may be requested to submit a compliance letter within 15 days detailing corrective action the carrier will take to correct violations found. Companies may be rechecked at a future date to ensure compliance.

Safety Profiles

A carrier's safety profile is generated upon completion of a Compliance Review. The carrier profile consists of the following:

- Carrier Safety Rating
- Current Insurance Status

Carrier profiles are maintained by the UTC on the following industries:

- Charter/Excursion Companies (WAC 180-20-031 requires school districts to obtain a carrier profile from the UTC before contracting with a Charter Bus/Excursion Bus company)
- Auto Transportation Companies
- Private Non-profit Passenger Carriers
- Household Goods Carriers
- Solid Waste Carriers

To obtain a carrier profile from the UTC, contact:

Washington Utilities and Transportation Commission:
carrierprofilerequests@utc.wa.gov

To obtain an interstate carrier safety profile, contact:

Federal Motor Carrier Safety Administration
(360) 753-9875

UTC SAMPLE CARRIER PROFILE REPORT**Washington Utilities and Transportation Commission Safety Profile**

DATE [month day, year]

COMPANY [Company]

CERTIFICATE CH[#####]

USDOT [#####]

INSURANCE Valid insurance on file with UTC

SAFETY RATING - SATISFACTORY

A carrier's permit status can change quickly due to suspensions or cancellations. Check the current status of a permit by visiting the commission's [permitted carrier website](#). Contact the commission via email at CarrierProfileRequests@utc.wa.gov, or by phone at (360) 664-1244 for an updated carrier profile report.

Sincerely,

Motor Carrier Safety
Transportation Safety Division

Section 13

Suggestions For Establishing An Effective Safety Program

DEVELOPING A RISK MANAGEMENT OR SAFETY PLAN

The cornerstone of a good company safety effort is a risk management or safety plan.

This written document sets out your company policy and procedures. It need not be a complicated document, but something that conveys how your company handles the hiring process, keeps vehicles in good condition, and spells out rules of conduct for employees.

Even an owner-operator will benefit from written procedures such as those describing the vehicle inspection, repair, and maintenance process.

There are many benefits for coming up with a written safety plan. It puts all of your employees on the same playing field and lets them know what is acceptable and non-acceptable behavior. It answers questions about what should be done in certain situations such as qualifying drivers, accident response, or time intervals for preventive maintenance.

Safety plans could help to limit your liability in a lawsuit as it details your commitment to safety and shows that you will enforce your own policies to keep your operation safe.

There are four main points that you should address in your safety plan:

1. Showing how your drivers are qualified to operate commercial vehicles.
2. Describing how your vehicles are maintained in safe operating condition.
3. Documenting how your drivers are complying with the maximum hours of service requirements.
4. Describing how drivers and other employees receive a timely warning for violating the FMCSRs and setting forth a progressive disciplinary policy.

You will have substantial latitude in how you comply with some of the federal motor carrier safety regulations (FMCSRs). If you can simplify the regulations to meet your needs, you will more easily understand them and get your company into substantial compliance quickly.

Let your safety records do the talking ... beginning with a strong foundation in a safety plan! Remember, your fleet is unique, so when you are looking at guidelines for a general safety plan outline, keep that in mind and work these four major sections around your operations.

The Introduction and Policy – Part 1

Start your safety plan with a brief outline of your operation. Describe what you do and some background on the company. Try to include your company mission statement, if you have one. Add the responsibilities of management and the commitment towards safety throughout the organization. Show who the persons responsible for safety are, and include a brief description of their duties and qualifications. You should also point out how you communicate with other employees (i.e., safety meetings, orientations, on-the-job training, daily briefings or contacts, etc.) for the purpose of forwarding information on safety policies and procedures to be used.

The Hiring, Training, and Retention Process for Employees – Part 2

This section will provide a description of how you locate and recruit potential employees and the minimum requirements that you have set for selecting a driver.

Your orientation of new employees should be found in this part. Describe what you do to pass along company policies and procedures, work rules, what is your on-going communication policy with employees.

If you have on-the-job or formal training, include that information in this section. Show how training, on-going courses, meetings, or other safety-related matters are addressed and planned.

Once you have hired an employee, you should strive to retain them because you have a big investment just in the hiring and orientation process itself. Describe what the company does to retain drivers, including incentives, benefits, and employee recognition programs.

Be sure to address non-driving positions such as dispatchers or mechanics.

Include information on some of the required records that are kept on employees (i.e., driver qualification files, controlled substance/alcohol testing, time records/hours of service, disciplinary procedures). Explain their intended use and show who has control of them.

Equipment Inspection, Repair and Maintenance – Part 3

This part of the safety plan discusses your efforts to effectively manage equipment selection, inspection, repair, and maintenance.

You can start by describing the equipment that you use and its intended use. Does the equipment fit the need?

Describe briefly the process for routine vehicle inspections to ensure that your equipment is operating at levels you have deemed necessary. This should include the requirements for pre-trip and post-trip inspections as well as periodic inspections.

You should describe the program you use to ensure that routine maintenance is performed on schedule and according to accepted industry practices. Make notations of the recommended service intervals and what work is normally performed during each type of service. Many motor carriers use manufacturer's specifications or a time/mileage interval based on the type of operations.

One of the most important parts of the safety plan will be the discussion of what processes and procedures your company employs to ensure that any necessary repairs are properly made in accordance with your own, or industry, standards. In other words, if a driver reports a defect to equipment, you need to show that it was repaired. Show the communication between the driver, mechanic, and management in this process. You should also describe the programs for routine maintenance and routine vehicle inspection, including processes and procedures that will be used for owner-operators. **Remember, if the repair or service was not documented – it wasn't done!** Note the qualifications or minimum standards for your annual inspectors and brake inspectors. Your mechanics and outside vendors need to be qualified to be working on your commercial motor vehicle.

Close this part of the plan with a complete discussion of the records that are maintained on each vehicle describing the inspection, repair, and maintenance process. This would include what goes into the maintenance record, the driver/vehicle inspection report process, the requirement for a periodic (annual) inspection, and how results of roadside or terminal inspections performed by law enforcement or regulatory agencies are handled.

Management Systems – Part 4

Management personnel or owners should take the lead in ensuring that the safety performance of the fleet is periodically assessed, evaluated, and improved where needed. You should be able to document how you evaluate and demonstrate compliance with the FMCSRs.

In this part of the safety plan, discuss how you measure compliance in the following areas:

- **Hours of service.** Show that your drivers are complying with the hours-of-service requirements. Make sure a competent person is monitoring your records to prevent hours violations or form and manner errors. Discuss what the company does to combat driver fatigue (i.e., scheduling, training, off-duty time, etc.)
- **Qualified drivers.** Discuss how you periodically monitor or audit your driver qualification files to make sure they are current and your drivers are properly qualified.
- **Equipment operation.** Indicate how your inspection, repair, and maintenance procedures are set up. Is management actively involved in this process and are you keeping track of repairs to determine if your maintenance intervals and equipment specifications are up to par?
- **Monitoring/self-auditing.** Show what the company is doing to ensure compliance with the regulations. Provide examples of your monitoring process and show how often self-audit or assessments are performed. This setup can give you early warning of violations of company policies/procedures or of the FMCSRs. Don't get yourself in a position where you rely on law enforcement or regulatory authorities to perform this task for you.

Management should use all tools available to make a fair assessment of your company safety program. You can review and analyze accident data available from states, police agencies, or insurance companies to detect trends in crash causes. Consider setting up an internal accident review committee.

You can compare your company with others in the industry. Obtain a copy of your federal motor carrier safety profile and compare your operation with other similar companies in your industry. **Are your crash rates, out-of-service ratios, or violation numbers below the national average?**

If you aren't actively managing the drivers of vehicle operations on a daily basis, delegate someone in your organization that is responsible for the safety effort. Make your drivers, dispatchers, mechanics, and other personnel accountable for their actions. Demonstrate how changes in your safety efforts are implemented and following through with consequences and enforcement procedures for noncompliance.

Performing a review or self-audit of your operations on a regular basis can shed light on what you are doing right and what can be changed to get your company into compliance with the safety regulations. Make it a working tool – one that will work to make your operation safe and save you money through less downtime, fewer crashes, and high employee morale. People enjoy working for companies that put safety in the forefront. It shows that you are a responsible employer and that you really care about the health and welfare of your workers.

NOTE: This publication not intended for sale.

Section 14

Marking of Vehicles

The following are the marking requirements for vehicles permitted by the UTC and operated exclusively in **Intrastate** commerce. For interstate marking requirements, refer to Title 49, CFR, Part 390.21.

Household Goods Carriers (WAC 480-15-560 (2))

- Carrier's permit name and number.
- Displayed on both the driver and passenger doors of the power unit.
- Clearly legible.
- No less than three inches high.
- In colors that contrast with the background color.
- Permanent markings. Carriers may use temporary markings for leased vehicles.
- Carriers with both intrastate and interstate authority must display either the UTC permit number, federal permit number, or both on the power unit.

Common Carriers (RCW 81.80.305)

- Carrier's permit name or number, or both.
- Displayed on each side of each power unit.
- Clearly legible.
- Letter no less than three inches high.
- Colors must contrast with the surrounding body panel.
- Permanent markings. Leased vehicles may display either permanent markings or placards on the driver and passenger doors of the power unit.
- Common carrier holding both intrastate and interstate authority may display either the USDOT certificate number, UTC permit number, or both.

Solid Waste Carriers (WAC 480-70-206)

- Carrier's certificate name and/or registered trade name, and certificate number.
- Displayed on each side of the vehicle.
- Clearly legible.
- Permanent markings except for leased or substitute vehicles.

Passenger Transportation Companies (WAC 480-30-231)

- Carrier's certificate holder's name or registered trade name, and certificate number.
- Displayed on each side of the vehicle.
- A destination on each side of the vehicle.
- A destination sign is required for vehicles operating a scheduled, regular route service.
- Company identification or unit number.
- All identifications must be clearly legible, conspicuous, and of a size that is easily readable.
- Permanent markings except for leased or substitute vehicles.

Private, Nonprofit Transportation Providers (WAC 480-31-110)

- Registered provider name and certificate number.
- Displayed on the driver and passenger side of the vehicle.
- Clearly legible.
- Letters no less than three inches high.
- Displayed in a color that contrasts with the surrounding body panel.
- Permanent markings.
- Leased vehicles may display either permanent markings or placards on the driver and passenger sides of the vehicle.
- Providers holding both intrastate and interstate authority may display either the USDOT certificate number, UTC certificate number, or both.
- When the name of the provider would create an embarrassment to the person with special transportation needs, the name of the provider may be omitted when authorized by a letter from the secretary of the UTC.

Section 15

Bus Operations

WAC 392-144-040, Application to contractors.

- (1) Every contract between a school district and a private school bus contractor for pupil transportation services shall provide for compliance with the requirements of this chapter and establish the responsibility of the contractor or school district, or both, to assure compliance with such requirements.
- (2) Each driver employed by a private school bus contractor under contract with a school district to provide pupil transportation services shall meet the requirements of this chapter, and shall be subject to the denial, suspension, and revocation of authority to operate a motor vehicle under this chapter.
- (3) Every contract between a school district and a charter bus carrier or excursion carrier, or subcontracted carrier shall require a carrier profile report indicating a satisfactory rating from the Washington utilities and transportation commission before any service is provided. No driver under this subsection shall have unsupervised access to children. Supervision of children under this subsection shall be provided by a responsible employee of the school district.

CONFIGURING EMERGENCY EXITS ON BUSES

All emergency exits must be marked with:

- **Clearly legible signs indicating exit and method to open.**
- **The words “emergency door” or “emergency exit” @ least one inch high.**
- **Refer to the Emergency Exit Worksheet to determine bus exit space requirements for buses.**

Emergency Exit Worksheet

METHOD 1: WORKSHEET TO DETERMINE COMPLIANCE WITH BUS EXIT SPACE REQUIREMENTS (FOR BUSES MANUFACTURED AFTER SEPTEMBER 1, 1973)

I. CALCULATE TOTAL EMERGENCY EXIT SPACE REQUIRED:

- A. Number of mfg.-designated seating positions, including driver _____
- B. Multiply by 67 sq. in. per seat X 67 sq. in.
- C. Equals total emergency exit space required = _____ sq. in.

II. CALCULATE MINIMUM 40% REQUIRED FOR EACH SIDE:

- A. Total exit space required (from line IC) _____ sq. in.
- B. Multiply by 40% X .4
- C. Equals exit space required on each side of bus = _____ sq. in.

III. CALCULATE EXISTING EXIT SPACE ON BUS:

- A. LEFT SIDE:
 - _____ doors x 536 sq. in. for each _____ sq. in.
 - + _____ exit windows x * _____ (max 536) for each + _____ sq. in.
 - **Left subtotal = _____ sq. in.
- B. RIGHT SIDE:
 - One front entry door _____ 536 sq. in.
 - + _____ exit windows x * _____ (max 536) for each + _____ sq. in.
 - **Right subtotal = _____ sq. in.
- C. REAR / ROOF EXITS:
 - Rear exit door/window (if any, enter 536) _____ sq. in.
 - + _____ roof hatches x * _____ (max 536) for each + _____ sq. in.
 - Rear/roof subtotal = _____ sq. in.
- D. TOTAL EXIT SPACE PROVIDED (Add three subtotals) = _____ sq. in.

IIID MUST BE EQUAL TO OR GREATER THAN LINE IC.

*Enter actual size of unobstructed exit when fully opened. maximum 536.
 **Must be greater or equal to line IIC.



U.S. Department
of Transportation

**Pipeline and
Hazardous Materials Safety
Administration**

400 Seventh Street, S.W.
Washington, D.C. 20590

DOT GUIDANCE FOR THE SAFE TRANSPORTATION OF MEDICAL OXYGEN FOR PERSONAL USE ON BUSES AND TRAINS

The Department of Transportation recommends that bus and train operators take the following precautions to assure that medical oxygen being transported for passengers' personal use is handled and transported safely:

FOR TRANSPORTATION IN THE PASSENGER COMPARTMENT

- Only transport oxygen in a cylinder maintained in accordance with the manufacturer's instructions. The manufacturer's instructions and precautions are usually printed on a label attached to the cylinder.
- Before boarding, inspect each cylinder to assure that it is free of cracks or leaks, including the area around the valve and pressure relief device. Listen for leaks; do not load leaking cylinders on the bus or train. Visually inspect the cylinders for dents, gouges or pits. A cylinder that is dented, gouged, or pitted should not be transported.
- Limit the number of cylinders to be transported on board the vehicle to the extent practicable.
- Except in emergency situations, the bus or rail operator should consider limiting the number of passengers requiring medical oxygen.
- Cylinders used for medical oxygen are susceptible to valve damage if dropped. Handle these cylinders with care during loading and unloading operations. Never drag or roll a cylinder. Never carry a cylinder by the valve or regulator.
- Do not handle oxygen cylinders or apparatus with hands or gloves contaminated with oil or grease.
- Secure each cylinder to prevent movement and leakage. "Secured" means the cylinder is not free to move when the vehicle or train is in motion. Each cylinder should be equipped with a valve protection cap.

- Never store or secure oxygen cylinders or other medical support equipment in the aisle. Make sure that the seating of the passenger requiring oxygen does not restrict access to exits or use of the aisle.
- Since the release of oxygen from a cylinder could accelerate a fire, secure each cylinder away from sources of heat or potential sparks.
- Under **no** circumstances should smoking or open flames (cigarette lighter or matches) be permitted in the passenger compartment when medical oxygen is present.
- When you reach your destination, immediately remove all cylinders from the bus or train.

FOR TRANSPORTATION IN THE CARGO COMPARTMENT

- Place each cylinder in a box or crate or load and transport in an upright or horizontal position.
- Valves must be protected against damage, except when in use.
- Secure each cylinder against movement.
- The total weight for oxygen cylinders permitted in a bus cargo compartment is 45 kg (99 lbs). A carrier may elect to transport up to 200 kg (440 lbs) in the cargo compartment if the oxygen cylinders are necessary to protect the health and safety of the passengers. However, we strongly recommend limiting the total weight of the cylinders to 45 kg (99 lbs) except under extraordinary circumstances.
- Oxygen cylinders offered for transportation and transported in rail cars on a passenger train may not exceed 34 lbs (75 kg) gross weight per cylinder.

For further information, contact PHMSA's Hazardous Materials Information Center at 1-(800) 467-4922.



Robert A. McGuire
Associate Administrator for Hazardous Materials Safety

June 30, 2006

Section 16

Record Keeping Requirements of the Federal Motor Carrier Safety Regulation

CFR 49, Part 390.31, Copies of records or documents.

(a) All records and documents required to be maintained under this subchapter must be preserved in their original form for the periods specified, unless the records and documents are suitably photographed and the microfilm is retained in lieu of the original record for the required retention period.

(b) To be acceptable in lieu of original records, photographic copies of records must meet the following minimum requirements:

(b)(1) Photographic copies shall be no less readily accessible than the original record or document as normally filed or preserved would be and suitable means or facilities shall be available to locate, identify, read, and reproduce such photographic copies.

(b)(2) Any significant characteristic, feature or other attribute of the original record or document, which photography in black and white will not preserve, shall be clearly indicated before the photograph is made.

(b)(2) Any significant characteristic, feature or other attribute of the original record or document, which photography in black and white will not preserve, shall be clearly indicated before the photograph is made.

(b)(3) The reverse side of printed forms need not be copied if nothing has been added to the printed matter common to all such forms, but an identified specimen of each form shall be on the film for reference.

(b)(4) Film used for photographing copies shall be of permanent record type meeting in all respects the minimum specifications of the National Bureau of Standards, and all processes recommended by the manufacturer shall be observed to protect it from deterioration or accidental destruction.

(b)(5) Each roll of film shall include a microfilm of a certificate or certificates stating that the photographs are direct or facsimile reproductions of the original records. Such certificate(s) shall be executed by a person or persons having personal knowledge of the material covered thereby.

(c) All records and documents required to be maintained under this subchapter may be destroyed after they have been suitably photographed for preservation.

(d) Exception. All records except those requiring a signature may be maintained through the use of computer technology provided the motor carrier can produce, upon demand, a computer printout of the required data.

Recordkeeping Requirements of the Federal Motor Carrier Safety Regulations

The following table summarizes the recordkeeping requirements of the Federal Motor Carrier Safety Regulations under 49 CFR Parts 40, 382, 383, 387, and 390-399. See also §390.29 for general recordkeeping requirements, and §390.31 for information concerning photocopies.

TOPIC	DOCUMENT(S) TO BE RETAINED	RETENTION PERIOD	RETENTION LOCATION
Drugs & Alcohol (Parts 40 and 382)	<p>Records related to the education and training of:</p> <ul style="list-style-type: none"> • breath alcohol technicians (BATs), • screening test technicians (STTs), • supervisors, and • drivers. <p>Required documentation includes:</p> <ul style="list-style-type: none"> • Materials on drug and alcohol awareness, including a copy of company policy • Documentation of compliance with requirement to provide drivers with educational material, including driver's signed receipt of materials • Documentation of supervisor training • Documentation of BAT training (§40.51(a)) • Certification that training complies with the rules. <p>See §40.333 and §382.401.</p>	2 years after the individual ceases to perform those functions	<p>In a secure location with controlled access.</p> <p>Note: If combined with other files (personnel or driver qualification files, for example) then <u>all</u> the files must be secured.</p>
	<ol style="list-style-type: none"> 1. Alcohol test results* with concentration of 0.02 or more 2. Verified positive drug test results 3. Documentation of refusals 4. Calibration documentation 5. Evaluation and referral records, including: <ul style="list-style-type: none"> ○ Records pertaining to SAPs determination of a need for assistance ○ Records concerning a driver's compliance with SAPs recommendations. 6. Records related to program administration, including: <ul style="list-style-type: none"> ○ Agreements with collection sites, labs, BATs, MROs, and consortia ○ Names and positions of officials and their role in the employer's testing program ○ Semiannual laboratory statistical summaries of urinalysis (§40.111(a)) ○ Company testing policy and procedures 7. Annual calendar year summary 	5 years	

	<p>*Test results includes:</p> <ul style="list-style-type: none"> • Copy of alcohol test form, with results; • Copy of drug test chain of custody form; • Documents sent to the employer by the MRO; • Documentation of any refusal to submit; • Documents provided by a driver to dispute results; and • Previous employer test results (see §§382.301(c) and 40.25, outlined below) <p>See §40.333 and §382.401.</p>		
	<p>Records related to the collection process (except EBT calibration records):</p> <ul style="list-style-type: none"> • Collection logbooks (if used); • Documents related to the random selection process; • Documentation of BAT training; • Documentation of reasoning for reasonable suspicion testing; • Documentation of reasoning for post-accident testing; • Documents verifying a medical explanation for the inability to provide adequate breath or urine for testing; and • Consolidated annual calendar year summaries. <p>See §40.333 and §382.401.</p>	2 years	
	<p>1. Negative and cancelled drug test results* 2. Alcohol test results with concentration less than 0.02</p> <p>*Test results includes:</p> <ul style="list-style-type: none"> • Copy of alcohol test form, with results; • Copy of drug test chain of custody form; • Documents sent to the employer by the MRO; • Documentation of any refusal to submit; • Documents provided by a driver to dispute results; and • Previous employer test results (see §§382.301(c) and 40.25, below) <p>See §40.333 and §382.401.</p>	1 year	

	<p>For employers using the exception to pre-employment testing in §382.301(b):</p> <ul style="list-style-type: none"> Names and addresses of the testing programs in which the prospective employee participated; Verification that the driver participates or participated in the program(s); Verification that the program(s) conforms to Part 40; Verification that the driver is qualified under the rules of Part 40, including that the driver has not refused to be tested for controlled substances; The date the driver was last tested for controlled substances; and The results of any tests taken within the previous six months and any other violations of Subpart B. <p>Note: An employer who uses but does not employ a driver more than once per year to operate CMVs must obtain the above information at least once every six months.</p> <p>See §382.301(c).</p>	5 years for any positive results, 1 year for negative results	
Driver Training (Part 380)	Entry-level driver training certificate (§380.509).	Employment + 1 year	Personnel or Driver Qualification file
	Longer Combination Vehicle (LCV) Driver-Training Certificate (§380.401) or Certificate of Grandfathering (§380.111).	Unspecified	Driver Qualification file
	LCV driver-instructor qualification file, including: <ul style="list-style-type: none"> Evidence that the instructor has met the requirements of §380.301 or 380.303; and A copy of the individuals currently valid CDL with the appropriate endorsements. (§391.55) 	For as long as the company employs or uses the instructor	LCV Driver-Instructor Qualification file or personnel file
CDLs (Part 383)	<p>Notification for conviction for driver violations. Must include the information listed in §383.31(c).</p> <p>Note: Notifications of CDL suspensions (§383.33) have no recordkeeping requirements.</p> <p>See §383.31 and the interpretations to §391.27.</p>	3 years	Driver Qualification file
Financial Responsibility (Part 387)	<ol style="list-style-type: none"> Form MCS-90 or MCS-82, or an FMCSA document authorizing self-insurance, for motor carriers. Form MCS-90B or MCS-82B for passenger carriers. <p>See §387.7(d) and §387.31(d).</p>	Continuously	Unspecified
Accidents (Part 390)	<ol style="list-style-type: none"> Accident register. Copies of accident reports required by states, other governmental entities, or insurers. <p>See §390.15(b).</p>	3 years (or one year for accidents occurring on or before 4/29/03)	Unspecified

<p>Driver Qualification (Part 391)</p>	<ol style="list-style-type: none"> 1. Application for employment (§391.21), 2. Motor vehicle record from states (§391.23) (must be obtained within 30 days of employment), 3. Road test form and certificate (§391.31(g)), or license or certificate accepted in lieu of road test (§391.33), 4. Medical exam certificate (original or a copy)* (§391.43(g)), 5. Any letter granting a waiver of a physical disqualification*, 6. Annual review of driving record* (§391.25), 7. List of violations* (§391.27), 8. Any other matter relating to a drivers qualifications or ability to drive a motor vehicle safely, 9. Previous-employer inquiries for drivers hired before October 30, 2004 (§391.23), and 10. Certificate of training, for drivers transporting highway route controlled Class 7 (radioactive) materials (§397.101(e)). <p>*The following may be removed 3 years after execution:</p> <ul style="list-style-type: none"> • Medical examiner's certificate, • Annual motor vehicle record from state(s), • Note relating to annual review of driving record, • Annual list of violations (prepared by the driver), and • Letter granting a waiver of a physical disqualification. <p>See §391.51.</p>	<p>Employment + 3 years</p>	<p>Driver Qualification file</p> <p>Note: May be combined with personnel file.</p> <p>Note: The long medical exam form is to be kept in the office of the medical examiner (see Medical Qualification, below).</p>
	<p>Safety performance history of driver/applicants (i.e., previous employer information), including name and address, date of contact (or attempts made), and information received about a driver/applicant (§391.23) (must be placed into file within 30 days of hire).</p> <p>A copy of the drivers written authorization for the motor carrier to seek information about a drivers alcohol and controlled substances history as required under §391.23(d).</p> <p>Corrections or rebuttals received from former or current drivers concerning their safety performance histories (§391.23(j)) (should be placed in appropriate file where corrected or rebutted information is stored).</p> <p>NOTE: Drug/alcohol inquiries sent to a drivers former employer(s) in compliance with §391.23 are deemed to be in compliance with the inquiries required under §40.25(b).</p>	<p>Employment + 3 years</p>	<p>Driver Investigation History File in a secure location with controlled access</p> <p>Note: May be combined with personnel file, Driver Qualification file, Drug/Alcohol file, etc., but must be in a secure location with limited access.</p>

	A record of each inquiry received from other employers concerning a drivers safety performance history, and the response, including the date, the party to whom it was released, and a summary identifying what was provided (§391.23(g)(4)).	One year	Unspecified
Multiple-employer drivers (Part 391)	Keep the following records for a multiple-employer driver: <ul style="list-style-type: none"> • Medical exam certificate, original or a copy (§391.43(g)), • Road test form and certificate (§391.31(g)), or license or certificate accepted in lieu of road test (§391.33), • Driver's name and social security number, and • Identification number, type, and issuing state of motor vehicle operator's license. See §391.63.	Employment + 3 years	Driver Qualification file
Drivers from other employers (Part 391)	For drivers furnished by other motor carriers, keep the signed certificate required in §391.65(a)(2). See §391.65.	3 years	Driver Qualification file
Medical Qualification (Part 391)	Driver must carry the original or a copy of the medical examiners certificate. Note: The medical long form is not required. The long form is supposed to stay in the medical examiners files (see the last paragraph of Instructions for performing and Recording Physical Examinations in §391.43). See §391.41(a).	Continuously	On drivers person
Hours of Service (Part 395)	For all 100-air-mile-radius drivers, accurate and true time records showing: <ul style="list-style-type: none"> • The time the driver reports for duty each day, • The time the driver is released from duty each day, • Total number of hours on duty each day, and • Total time on duty for the preceding 7 days for drivers used for the first time or intermittently. See §395.1(e)(5).	6 months	Unspecified
	For drivers used intermittently, a signed statement giving: <ul style="list-style-type: none"> • The total time on duty during the immediately preceding 7 days, and • The time at which the driver was last relieved from duty. See §395.8(j)(2).	6 months	Unspecified
	Records of duty status (driver logs) and all supporting documents. Supporting documents are listed in Question 10 in the interpretations to Sec. 395.8. Logs must be submitted within 13 days of completion (§395.8(i)). See §395.8(k)(1).	6 months from date of receipt	Unspecified

	<p>A copy of each log for the previous 7 consecutive days (whether hand-written or electronic)</p> <p>See §395.8(k)(2) and §395.15(b)(4).</p>	7 days	In vehicle
	<p>For companies using on-board recording devices that use location codes instead of city/state information, a list of the location codes showing all possible location identifiers.</p> <p>See §395.15(d)(2).</p>	Unspecified	In vehicle and at principal place of business.
	<p>For drivers using on-board recording devices:</p> <ul style="list-style-type: none"> • An instruction sheet describing in detail how data may be stored and retrieved from the automatic on board recording system; and • A supply of blank drivers records of duty status graph grids sufficient to record the drivers duty status and other related information for the duration of the current trip. <p>See §395.15(g).</p>	Unspecified	In vehicle
	<p>For companies using on-board recording devices, a certificate obtained from the manufacturer certifying that the design of the automatic on board recorder has been sufficiently tested to meet the requirements of this section and under the conditions it will be used.</p> <p>See §395.15(i)(1).</p>	Unspecified	Unspecified
	<p>For companies using on-board recording devices, a second (back-up) copy of the electronic hours-of-service files, by month.</p> <p>See §395.15(i)(10).</p>	6 months	A different physical location than where the original data is stored
Inspections/ Maintenance (Part 396)	<p>For any motor vehicle controlled for 30 days or more:</p> <ul style="list-style-type: none"> • An identification of the vehicle including co. number (if so marked), make, serial number, year, and tire size, and vehicle owners name if the motor carrier does not own the vehicle; • A means to indicate the nature and due date of the various inspection and maintenance operations to be performed; • A record of inspection, repairs and maintenance indicating their date and nature; and • A record of tests conducted on pushout windows, emergency doors, and emergency door marking lights on buses. <p>See §396.3(b).</p>	1 year and for 6 months after the vehicle leaves your control	Where the vehicle is either housed or maintained
	<p>Copy of roadside inspection form.</p> <p>See §396.9(d)(3)(ii).</p>	12 months from date of inspection	Principal place of business or where vehicle is housed

	<ol style="list-style-type: none"> 1. Original DVIR (drivers vehicle inspection report), 2. Certificate of repairs, and 3. Certification of drivers review. <p>Note pre-trip requirements in §392.7 and §396.13. Only §396.13 has recordkeeping requirements.</p> <p>See §396.11(c)(2) and Question 18 in the interpretations.</p>	3 months	Principal place of business or where vehicle is housed or maintained
	Documentation of periodic inspection (a report or other document such as a sticker or decal).	Continuously	In or on vehicle
	Evidence of an individuals qualifications to conduct annual inspections.	Until 1 year after employee stops performing inspections	Unspecified
	Periodic inspection report (original or copy).	14 months	Where the vehicle is housed or maintained
	Evidence of a brake inspectors qualifications.	Until 1 year after employee stops performing inspections	Principal place of business or where employee is based
Hazmat (Part 397)	Signed receipt documenting that hazmat driver has received a copy of the regulations and emergency instructions per §397.19(a). Applies to transportation of explosives only. See §397.19(b).	1 year	Unspecified
	A written route plan, for transporting highway route controlled Class 7 (radioactive) materials, per §397.101(d).	Unspecified.	In drivers possession, and filed with the FMCSA and shipper.
	Certificate of training, for drivers transporting highway route controlled Class 7 (radioactive) materials, per §397.101(e).	Employment + 3 years	Driver Qualification file, and in drivers immediate possession
Other (Part 379)	Business records. See Part 379 for details. This regulation is a holdover from when the Interstate Commerce Commission regulated trucking (before the FMCSA was created).	See regulation	See regulation

Section 17

Leasing Requirements

HHG CARRIERS**WAC 480-15-590**
Lease responsibilities

A carrier must enter into an equipment lease agreement before operating a leased motor vehicle. The carrier must ensure that all of the following conditions are met:

- (1) The carrier signs the form and ensures the lessor signs the form.
- (2) The carrier marks "master lease" if the carrier intends to use a master lease instead of individual leases.
- (3) A copy of the lease is carried in all leased motor vehicles.
- (4) Copies of all leases are kept in the carrier's permanent files for at least one year after the lease expires.
- (5) The carrier gives a copy of the lease to the owner of the leased motor vehicle.
- (6) The carrier takes possession, control and use of the motor vehicle during the period of the lease agreement.
- (7) The leased motor vehicle is properly insured as specified in WAC 480-15-530 and 480-15-550.
- (8) The carrier properly identifies the motor vehicle as specified in RCW 81.80.305.
- (9) The carrier charges appropriate tariff rates and charges.
- (10) The driver of the leased motor vehicle is on the carrier's payroll during the leased period.
- (11) The leased motor vehicle is operated in compliance with laws and rules as specified in WAC 480-15-560 and 480-15-570.
- (12) The driver of the leased motor vehicle is subject to the company's alcohol and controlled substance policies.
- (13) The carrier and the owner of the leased motor vehicle specify on the lease form who is responsible for all expenses relating to the leased motor vehicles.
- (14) The carrier complies with the terms of the lease.

PASSENGER VEHICLES**WAC 480-30-236**
Leasing vehicles

- (1) A passenger transportation company operating a leased vehicle must have a written lease agreement with the owner of the vehicle.
- (2) It is the company's responsibility to ensure that:
- (a) A copy of the lease is carried in each leased vehicle, unless the vehicle's registration names the certificate holder as registered owner or lessee;
 - (b) A copy of the lease is kept in the company's files during the effective period of the lease and for at least one year after the lease expires;
 - (c) A copy of the lease is provided to the owner of the leased vehicle;
 - (d) The company has complete possession, control, and use of the motor vehicle at all times during the period of the lease;
 - (e) The leased motor vehicle is properly insured as specified in WAC [480-30-191](#);
 - (f) The leased vehicle is properly identified as specified in WAC [480-30-231](#);
 - (g) The leased vehicle is operated in compliance with all safety laws and rules, including those regarding vehicle inspection, records, and maintenance; and
 - (h) The terms of the lease are followed.
- (3) If a company leases a vehicle with a driver, the company must also ensure that:
- (a) The driver of the leased motor vehicle is on the company's payroll during the lease period;
 - (b) The driver operates in compliance with all driver qualification, safety and hours of service laws and rules;
 - (c) The driver is subject to the company's alcohol and controlled substance policies; and
 - (d) The company maintains appropriate files and paperwork on the driver for a period of at least one year following the expiration of the lease.
- (4) The company and the owner of the leased vehicle must specify in the lease who is responsible for all expenses relating to the leased motor vehicle. The lease must contain all information shown in the following sample lease form. If a company uses an alternate form, the company must ensure the alternate form contains all information requested on the sample. These requirements do not apply to substitute vehicles or vehicles leased without drivers from a person principally engaged in the business of leasing vehicles.

SOLID WASTE VEHICLES**WAC 480-70-211**
Leasing vehicles

- (1) A company operating a leased vehicle must have a written lease agreement with the owner of the vehicle.
- (2) It is the company's responsibility to ensure that:
 - (a) A copy of the lease is carried in each leased vehicle;
 - (b) A copy of the lease is kept in the company's files during the effective period of the lease and for at least one year after the lease expires;
 - (c) A copy of the lease is provided to the owner of the leased vehicle;
 - (d) The company has complete possession, control, and use of the motor vehicle during the period of the lease;
 - (e) The leased motor vehicle is properly insured as specified in WAC [480-70-181](#);
 - (f) The leased vehicle is properly identified as specified in WAC [480-70-206](#);
 - (g) The leased vehicle is operated in compliance with all safety laws and rules, including those regarding vehicle inspection, records, and maintenance; and
 - (h) The terms of the lease are followed.
- (3) If a company leases a vehicle with a driver, the company must also ensure that:
 - (a) The driver of the leased motor vehicle is on the company's payroll during the lease period;
 - (b) The driver operates in compliance with all driver qualification, safety and hours of service laws and rules;
 - (c) The driver is subject to the company's alcohol and controlled substance policies; and
 - (d) The company maintains appropriate files and paperwork on the driver for a period of at least one year following the expiration of the lease.
- (4) The company and the owner of the leased vehicle must specify in the lease who is responsible for all expenses relating to the leased motor vehicle. The lease must contain all information shown in the following sample lease form. If a company uses an alternate form, the company must ensure the alternate form contains all information requested on the sample.

Section 18

CSA

(Compliance, Safety & Accountability)

CSA COMPLIANCE SAFETY & ACCOUNTABILITY

Compliance, Safety, Accountability (CSA) is a Federal Motor Carrier Safety Administration (FMCSA) initiative to improve large truck and bus safety and ultimately reduce crashes, injuries, and fatalities that are related to commercial motor vehicles.

Carriers are scored from data collected from on-road enforcement.

Measurement - CSA measures safety performance, using inspection and crash results to identify carriers whose behaviors could reasonably lead to crashes.

Evaluation - CSA helps FMCSA and its State Partners to correct high-risk behavior by contacting more carriers and drivers—with interventions tailored to their specific safety problem, as well as a new Safety Fitness Determination methodology.

Intervention - CSA covers the full spectrum of safety issues, from how data is collected, evaluated, and shared to how enforcement officials can intervene most effectively and efficiently to improve safety on our roads.

Within the Compliance, Safety, Accountability (CSA) Operational Model, the Safety Measurement System (SMS) quantifies the on-road safety performance of carriers and drivers to identify candidates for interventions, determine the specific safety problems that a carrier or driver exhibits, and to monitor whether safety problems are improving or worsening. SMS has replaced SafeStat in the new Operational Model.

SMS uses a motor carrier's data from roadside inspections, including all safety-based violations, State-reported crashes, and the Federal motor carrier census to quantify performance in the following Behavior Analysis and Safety Improvement Categories (BASICS).

CSA BASICS:

Unsafe Driving — Operation of commercial motor vehicles (CMVs) by drivers in a dangerous or careless manner. *Example violations:* Speeding, reckless driving, improper lane change, and inattention. (FMCSR Parts 392 and 397)

Hours-of-Service (HOS) Compliance — Operation of CMVs by drivers who are ill, fatigued, or in non-compliance with the HOS regulations. This BASIC includes violations of regulations pertaining to records of duty status (RODS) as they relate to HOS requirements and the management of CMV driver fatigue. *Example violations:* HOS RODS, and operating a CMV while ill or fatigued. (FMCSR Parts 392 and 395)

Driver Fitness — Operation of CMVs by drivers who are unfit to operate a CMV due to lack of training, experience, or medical qualifications. *Example violations:* Failure to have a valid and appropriate commercial driver's license (CDL) and being medically unqualified to operate a CMV. (FMCSR Parts 383 and 391)

Controlled Substances/Alcohol — Operation of CMVs by drivers who are impaired due to alcohol, illegal drugs, and misuse of prescription or over-the-counter medications. *Example violations:* Use or possession of controlled substances/alcohol. (FMCSR Parts 382 and 392)

Vehicle Maintenance — Failure to properly maintain a CMV and/or properly prevent shifting loads. *Example violations:* Brakes, lights, and other mechanical defects, failure to make required repairs, and improper load securement. (FMCSR Parts 392, 393 and 396)

Hazardous Materials (HM) Compliance — Unsafe handling of HM on a CMV. *Example violations:* Release of HM from package, no shipping papers (carrier), and no placards/markings when required. (FMCSR Part [397](#) and Hazardous Materials Regulations Parts 171, 172, 173, 177, 178, 179, and 180)

Crash Indicator — Histories or patterns of high crash involvement, including frequency and severity. It is based on information from State-reported crashes

A carrier's measurement for each BASIC depends on the following:

- The number of adverse safety events (violations related to that BASIC or crashes)
- The severity of violations or crashes
- When the adverse safety events occurred (more recent events are weighted more heavily).

After a measurement is determined, the carrier is then placed in a peer group (e.g., other carriers with similar numbers of inspections). Percentiles from 0 to 100 are then determined by comparing the BASIC measurements of the carrier to the measurements of other carriers in the peer group. A percentile 100 indicates the worst performance.

Intervention

The Federal Motor Carrier Safety Administration (FMCSA) and State Partners use measurement results to identify carriers for Compliance, Safety, Accountability (CSA) interventions. These interventions offer an expanded suite of tools ranging from warning letters to onsite comprehensive investigations. These tools supplement the former labor-intensive compliance review (CR) to better address the specific safety problems identified.

CSA investigators are equipped to systematically evaluate why safety problems are occurring, recommend remedies, encourage corrective action(s), and, where corrective action is inadequate, invoke strong penalties. Interventions provide carriers with the information necessary to understand their safety problems and to change unsafe behavior early on. Interventions under CSA are categorized into early contact, investigation, and follow-on, which are described in detail below.

Early Contact

Warning Letter - Correspondence sent to a carrier's place of business that specifically identifies an alerted Behavior Analysis and Safety Improvement Category (BASIC) and outlines possible consequences of continued safety problems. The warning letter provides instructions for accessing carrier safety data and measurement as well as a point-of-contact.

Carrier Access to Safety Data and Measurement - Carriers have access to their measurement results (BASICs scores), as well as the inspection reports and violations that went into those results. With this information, carriers can chart a course of self-improvement. Carriers can also monitor this data for accuracy and challenge it as necessary through FMCSA's DataQs system: <https://dataqs.fmcsa.dot.gov/login.asp>.

Targeted Roadside Inspection - CSA provides roadside inspectors with data that identifies a carrier's specific safety problems, by BASIC, based on the new measurement system. Targeted roadside inspections occur at permanent and temporary roadside inspection locations where connectivity to the SMS information is available. As Commercial Vehicle Information Systems and Networks (CVISN) technologies evolve, they will be incorporated into the roadside inspections.

Investigation

Offsite Investigation - A carrier is required to submit documents to FMCSA or a State Partner. These documents are used to evaluate the safety problems identified through the SMS and to determine their root causes. Types of documents requested may include third-party documents such as toll receipts, border crossing records, or drug testing records. The goal is to identify issues responsible for may be subject to an onsite investigation or to subpoena records (see below).

Onsite Focused Investigation - The purpose of this intervention is to evaluate the safety problems identified through the SMS and their root causes. An onsite focused investigation may be selected when alerts in one or two BASICs exist. Onsite "focused" investigations target specific problem areas (for example, maintenance records), while onsite "comprehensive" investigations address all aspects of the carrier's operation.

Onsite Comprehensive Investigation - This intervention is similar to a CR and takes place at the carrier's place of business. It is used when the carrier exhibits broad and complex safety problems through continually alerted BASICs, worsening multiple BASICs (three or more), or a fatal crash or complaint.

Follow-on

Cooperative Safety Plan (CSP) - Implemented by the carrier, this safety improvement plan is voluntary. The carrier and FMCSA collaboratively create a plan based on a standard template to address the underlying problems resulting from the carrier's substandard safety performance.

Notice of Violation (NOV) - The NOV is a formal notice of safety alerts that requires a response from the carrier. It is used when the regulatory violations discovered are severe enough to warrant formal action but not a civil penalty (i.e., a fine). It is also used in cases where the violation is immediately correctable and the level of, or desire for, cooperation is high. To avoid further intervention, including fines, the carrier must provide evidence of corrective action or initiate a successful challenge to the violation.

Notice of Claim (NOC) - An NOC is issued in cases where the regulatory violations are severe enough to warrant assessment and issuance of civil penalties.

Operations Out-of-Service Order (OOS) - An OOS order is an order requiring the carrier to cease all motor vehicle operations.

SAFETY MANAGEMENT CYCLE



The Safety Management Cycle (SMC) is the signature tool behind the Federal Motor Carrier Safety Administration's (FMCSA) investigative process. FMCSA designed the SMC to help Safety Investigators (SIs) and motor carriers improve safety by identifying and correcting safety performance and compliance issues.

*CHECK YOUR SMS SCORES ON A REGULAR BASIS:

www.fmcsa.dot.gov/sms

Type in your USDOT # and click on search

Check your SMS scores monthly

Familiarize yourself with this web site and CSA

Additional Resources:

FMCSA

<https://fmcsa.dot.gov>

FMCSA's Electronic Logging Device FAQ

<https://www.fmcsa.dot.gov/hours-service/elds/faqs>

FMCSA's Safety Planner

<https://csa.fmcsa.dot.gov/safetyplanner/>

FMCSA's Drug and Alcohol Clearinghouse

<https://clearinghouse.fmcsa.dot.gov/>

Washington State Patrol Commercial Vehicle Services

<https://www.wsdot.wa.gov/CommercialVehicle/default.htm>

Washington State Commercial Vehicle Drive

<https://www.wsdot.wa.gov/publications/manuals/fulltext/M30-39/CVG.pdf>

Washington Utilities and Transportation Commission

<https://www.utc.wa.gov/>

